

Instruction Manual

Drum Lifter



DL350

Note: The Owner/Operator must read carefully and understand all the information presented here before operation.

THANK YOU FOR USING THIS DRUM LIFTER. FOR YOUR SAFETY AND CORRECT OPERATION, PLEASE CAREFULLY READ THIS INSTRUCTION BEFORE USING IT.

NOTE: All of the information reported herein is based on data available at the moment of printing. The factory reserves the right to modify its own products at any moment without notice and incurring in any sanction. So it is suggested to always verify possible updates.

WARNING

- Read and understand the entire owner's manual before using the drum lifter.
- This drum lifter is designed for lifting drums in vertical position only.
- The drum must have a top lip.
- Do not load the drum lifter beyond its rated capacity of 750 lbs.
- Inspect the drum lifter before each use. If there is damage or distortion to any part, the drum lifter must be removed from service until it is repaired or replaced.
- Make sure the drum is secured by the lifting arms before raising.
- Do not allow anyone to stand beneath a raised drum.
- Never leave a drum unattended in the raised position.
- Do not use this drum lifter for other than its intended use.
- Failure to comply with these warnings may result in personal injury and/or property damage.

OPERATION OF DRUM LIFTER

1. Attach the drum lifter vertically to the hook of your hoist, chain block, etc.
2. Lower the drum lifter over the drum, and make sure the arms are secured evenly onto the rim of the drum to prevent the drum from

tilting.

- Carefully move the drum to desired location. When the drum has been lowered completely to the floor or pallet, allow the drum lifter to slacken and move it away from the drum.

SPECIFICATION

Capacity.....750 lbs.
 Drum Size.....55 gallon (210 liter)
 Net Weight.....10 lbs.

EXPLODED VIEW & PART LIST

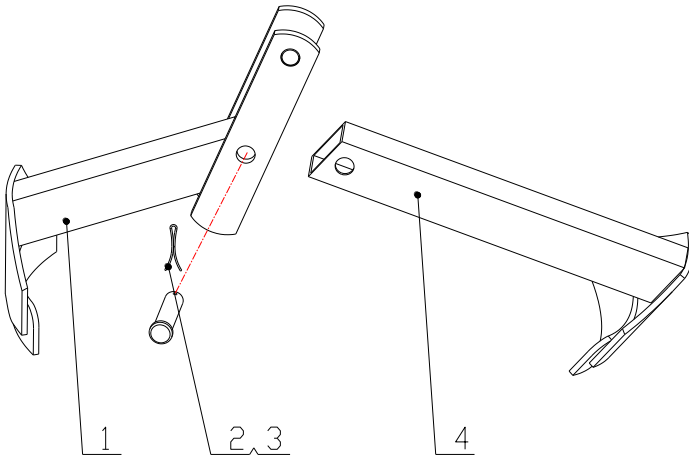

No.	Description	Size	Qty	Remark
1	Fixed arm		1	
2	Split pin	Φ 4 × 35mm	1	
3	Clevis pin	Φ 19 × 78mm	1	
4	Supporting pin		1	