

# Instruction Manual

## SKATES

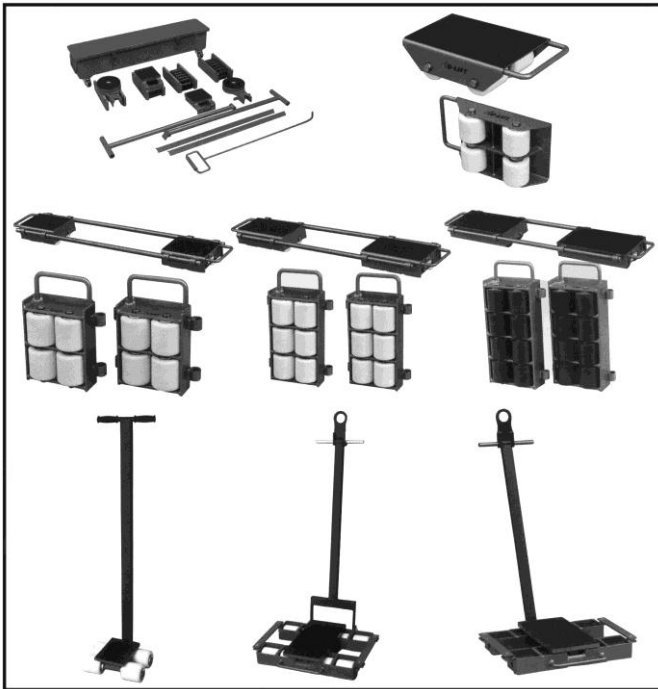

**Note:** Owner/Operator must read and understand this instruction manual before using the skates.

# **Contents**

**1. GENERAL DESCRIPTION**

**2. FEATURES**

**3. USES**

**4. EXPLODED FIGURES & PARTS LISTS**

THANK YOU FOR CHOOSING OUR PALLET TRUCK. FOR YOUR SAFETY AND CORRECT OPERATION, PLEASE CAREFULLY READ THE MANUAL BEFORE USE.

*NOTE: All of the information reported herein is based on data available at the time of printing. The factory reserves the right to modify its own products at any time without notice or incurring in any sanction. Please verify with the factory for possible updates.*

## **1. GENERAL DESCRIPTION**

Skates are ideal for all kinds of heavy equipment moving, machinery installation and maintenance.

## **2. FEATURE**

- 2.1 Low height, transport safety (7~20cm)
- 2.2 Weak pulling, transport easily (about 3% of overall load in ideal position)
- 2.3 Combine easily, strong adaptation (load 1~60T)
- 2.4 Small equipment, easy storage

## **3. USES**

- 3.1 Capacities of SF10, SF20, SF25, SF30, and SF60 are respective 1T, 2T, 2.5T, 3T, and 6T. Line-pull roller is suitable for pulling in straight-line fashion and turning.
- 3.2 Capacities of SC120 and SC104 are all 1T. They are respectively with two and four steering wheels and suitable for turned pulling.
- 3.3 CM60, CM120 and CM240 are combination, capacities of which are respectively 6T, 12T and 24T. They are suitable for pulling large goods.
- 3.4 ST30, ST60 and ST120 participate of pulling rollers. Their capacities are respectively 3T, 6T and 12T. They can be pulled to change direction.

3.5 SK20, SK30 and SK60 participate of chain rollers. Their capacities are respectively 20T, 30T and 60T. They can be pulled to change direction. They should be used on steel plate (thickness  $\geq 10\text{mm}$ ).

3.6 RC15 is a pry with a capacity of 1.5T and it is necessary accessory of above skates.

## 4. EXPLODED FIGURES & PARTS LISTS

### 4.1 Exploded figure of SF10 and parts list

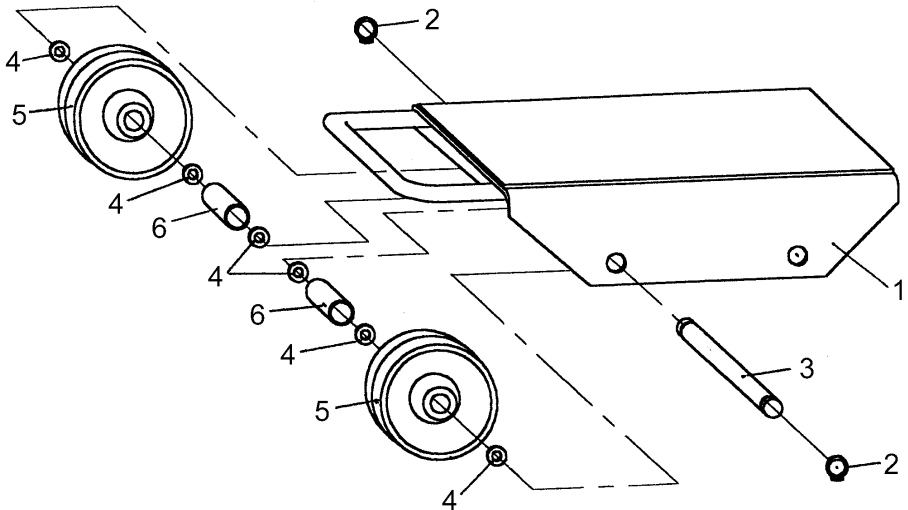

No.	Description	Q'ty
1	Frame	1
2	Retaining ring	4
3	Axle	2
4	Washer	12
5	Wheel	4
6	Bushing	4

### 4.2 Exploded figure of SF20 and parts list

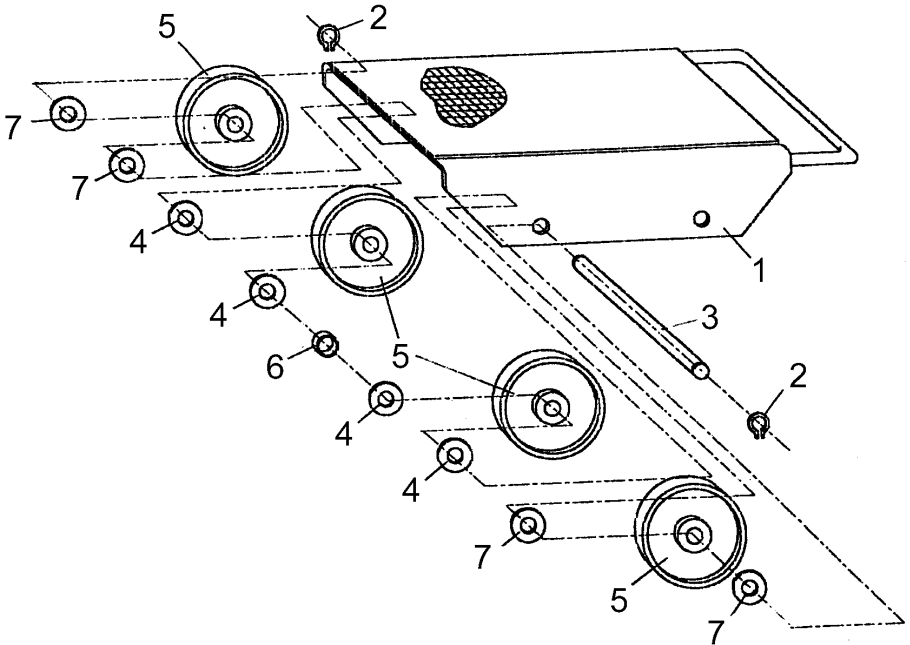

No.	Description	Q'ty
1	Frame	1
2	Retaining ring	4
3	Axle	2
4	Washer	8
5	Wheel	8
6	Bushing	2
7	Washer case	8

### 4.3 Exploded figure of SF25 and parts list

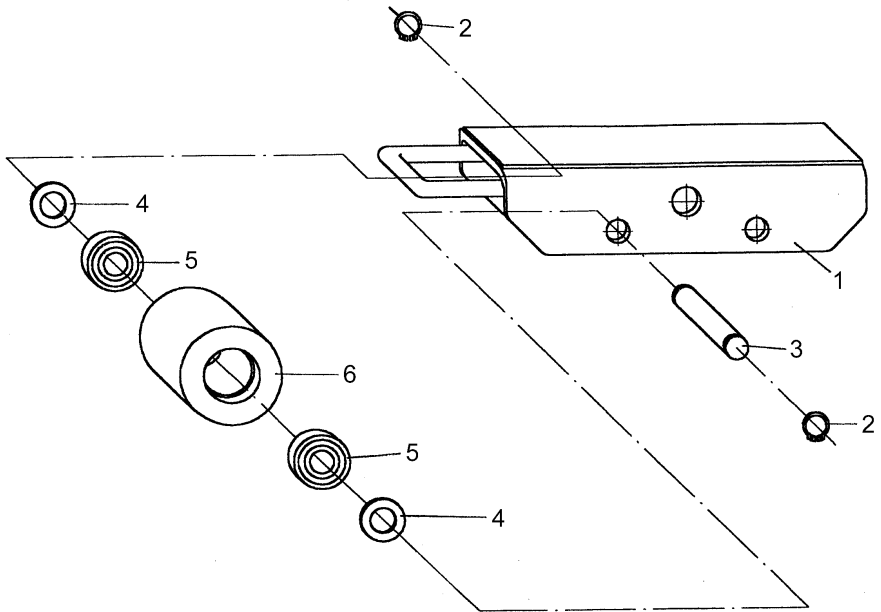

No.	Description	Q'ty
1	Frame	1
2	Retaining ring	4
3	Axle	2
4	Washer casing	4
5	Bearing	4
6	Roller	2

#### 4.4 Exploded figure of SF30 and parts list

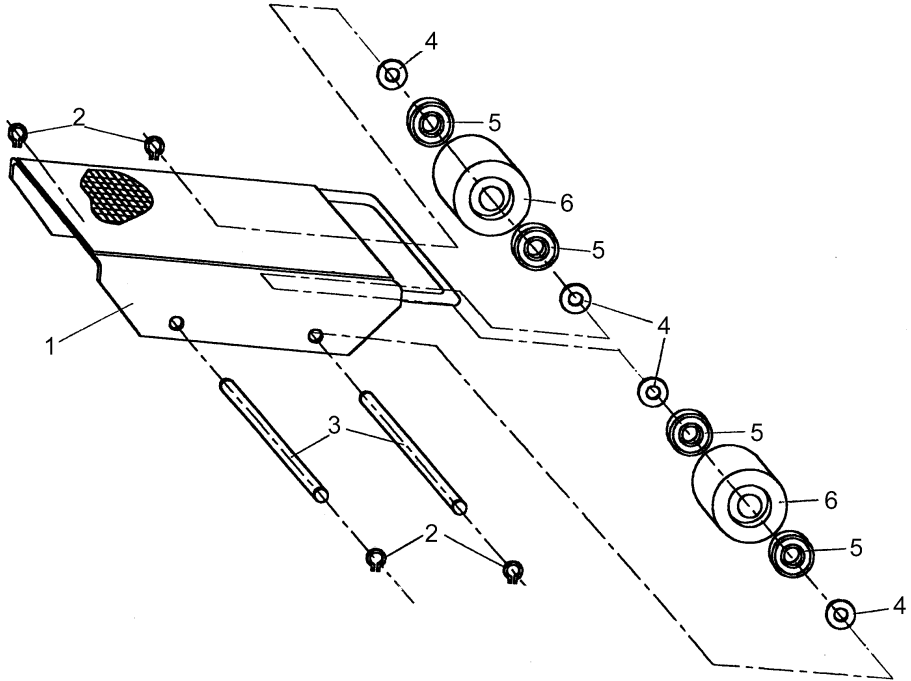

No.	Description	Q'ty
1	Frame	1
2	Retaining ring	4
3	Axle	2
4	Washer casing	8
5	Bearing	8
6	Roller	4

#### 4.5 Exploded figure of SF60 and parts list

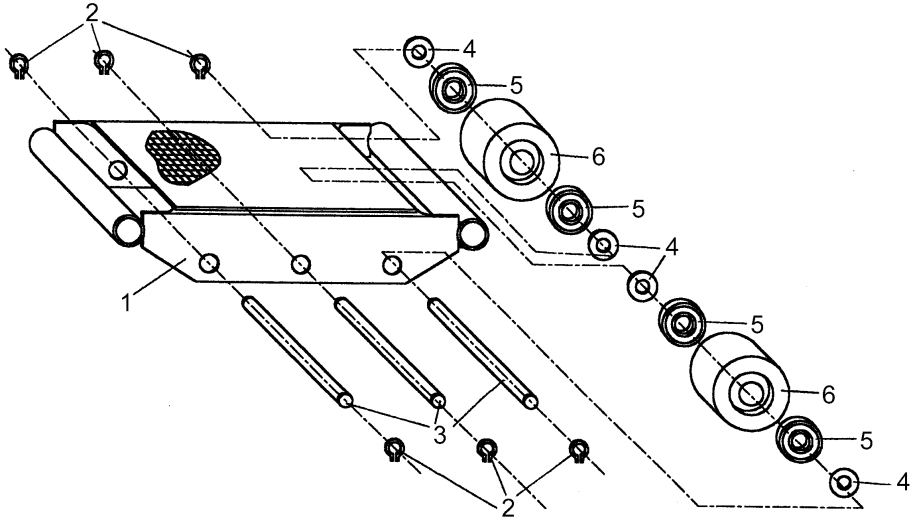

No.	Description	Q'ty
1	Frame	1
2	Retaining ring	6
3	Axle	3
4	Washer	12
5	Bearing	12
6	Roller	6



#### 4.6 Exploded figure of SC102 and parts list

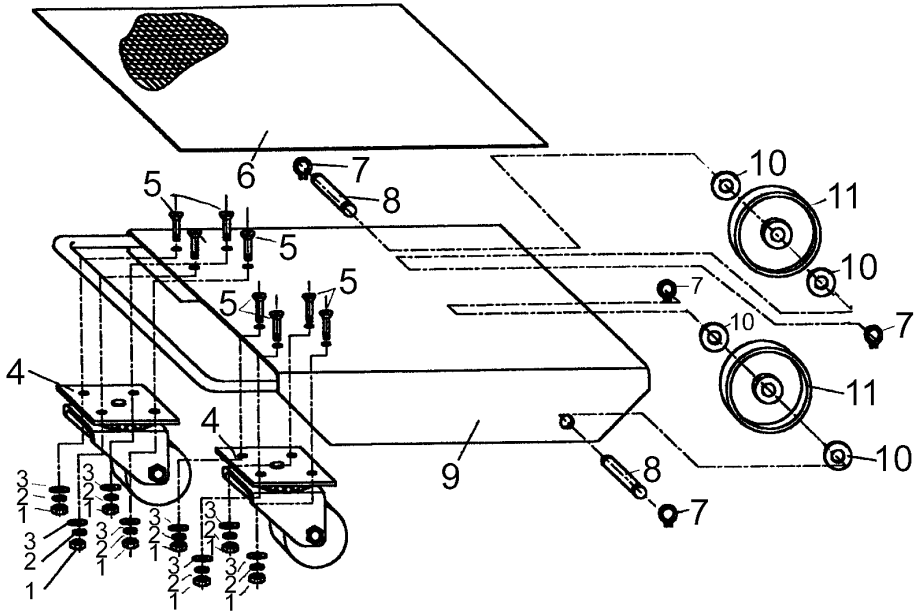

No.	Description	Q'ty
1	Nut	8
2	Spring washer	8
3	Flush washer	8
4	Wheel	2
5	Screw	8
6	Rubber plate	1
7	Retaining ring	4
8	Axle	2
9	Frame	1
10	Washer casing	4
11	Roller	2

### 4.7 Exploded figure of SC104 and parts list

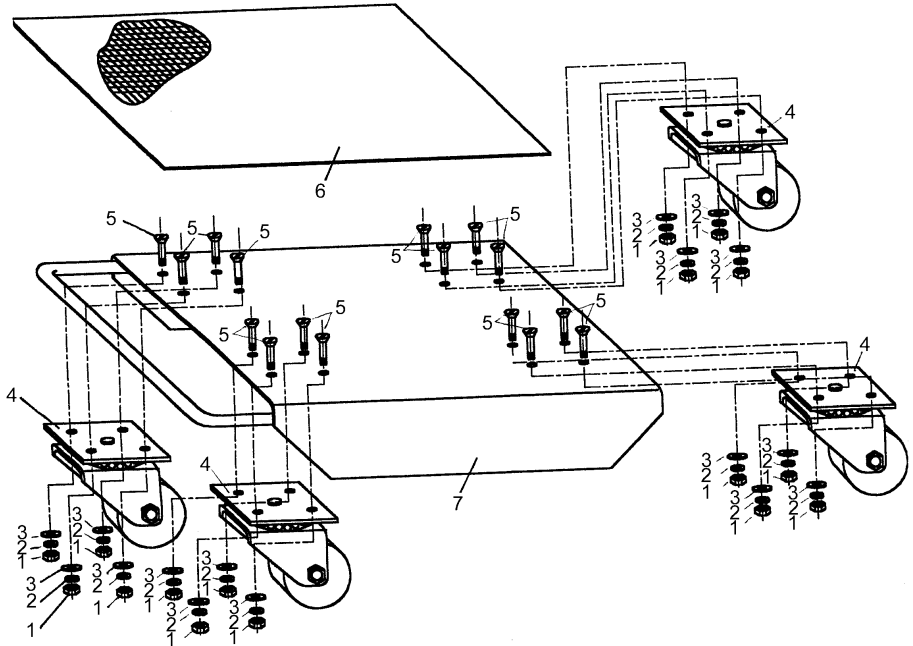

No.	Description	Q'ty
1	Nut	16
2	Spring washer	16
3	Flush washer	16
4	Wheel	4
5	Screw	16
6	Rubber plate	1
7	Frame	1

#### 4.8 Exploded figure of CM60 and parts list

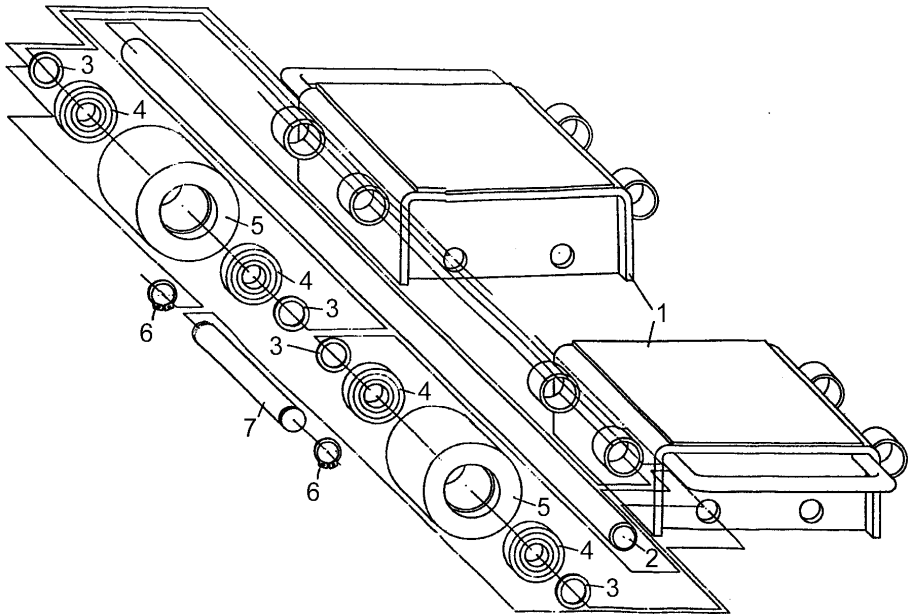

No.	Description	Q'ty
1	Frame	2
2	Rod	2
3	Washer	16
4	Bearing	16
5	Roller	8
6	Retaining ring	8
7	Axle	4

#### 4.9 Exploded figure of CM120 and parts list

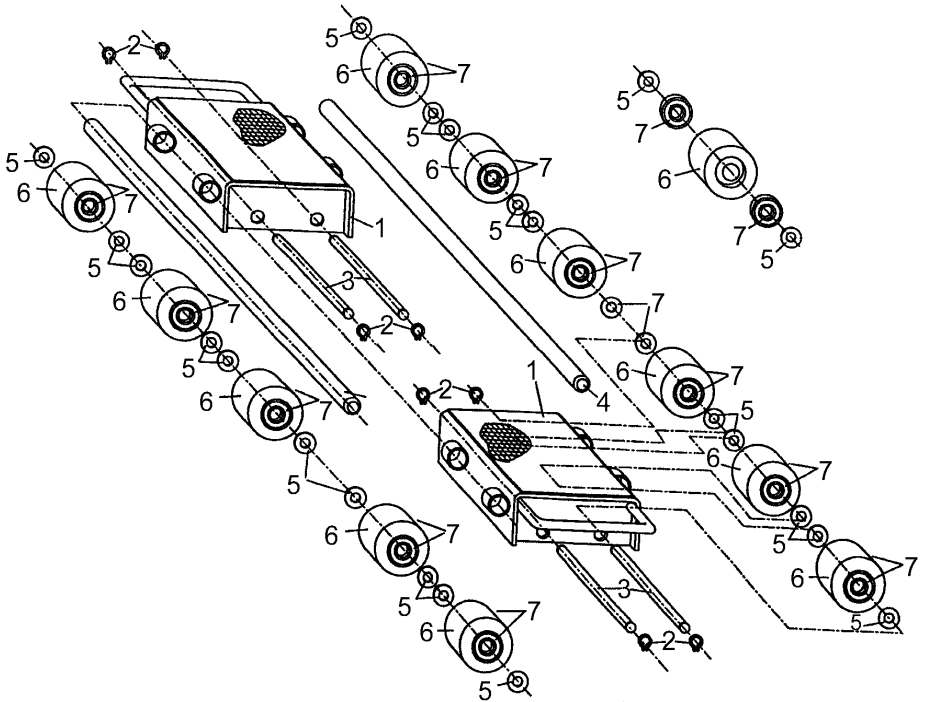

No.	Description	Q'ty
1	Frame	2
2	Retaining ring	8
3	Axle	4
4	Rod	2
5	Washer	24
6	Roller	12
7	Bearing	24

#### 4.10 Exploded figure of CM240 and parts list

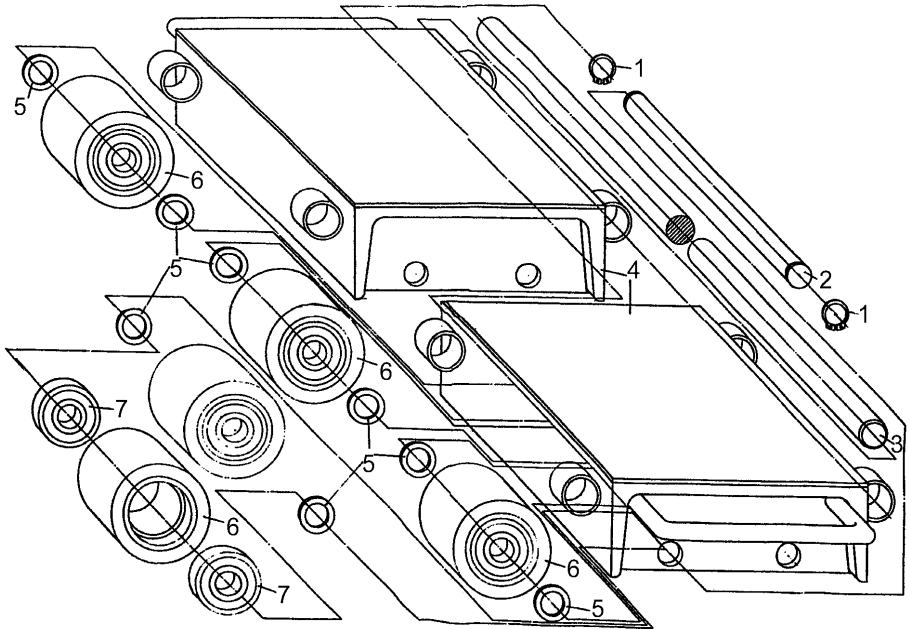

No.	Description	Q'ty
1	Retaining ring	8
2	Axle	4
3	Rod	2
4	Frame	2
5	Washer	32
6	Roller	16
7	Bearing	32

#### 4.11 Exploded figure of ST30 and parts list

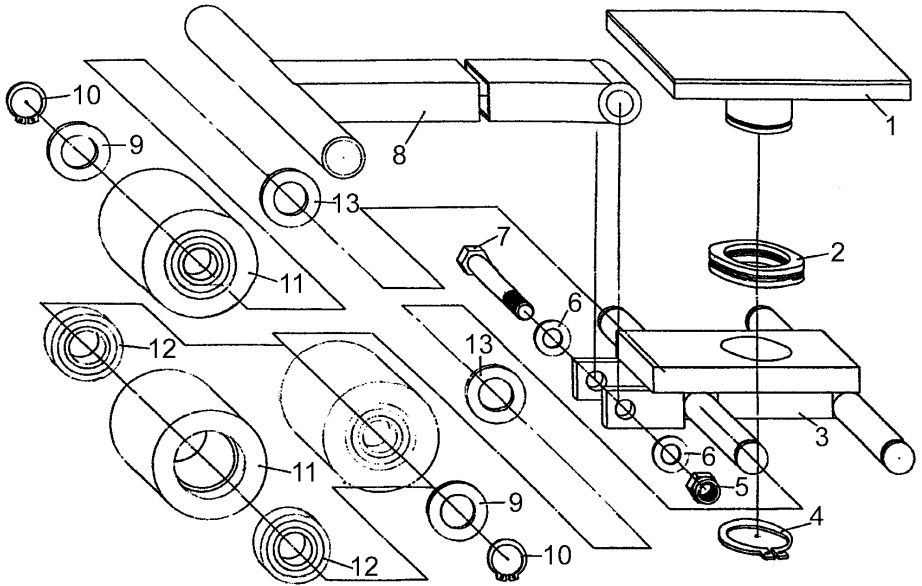

No.	Description	Q'ty
1	Frame	1
2	Bearing	1
3	Roller bracket	1
4	Retaining ring	1
5	Nut	1
6	Washer	2
7	Bolt	1
8	Welded handle	1
9	Washer	4
10	Retaining ring	4
11	Roller	4
12	Bearing	8
13	Washer casing	4

#### 4.12 Exploded figure of ST60 and parts list

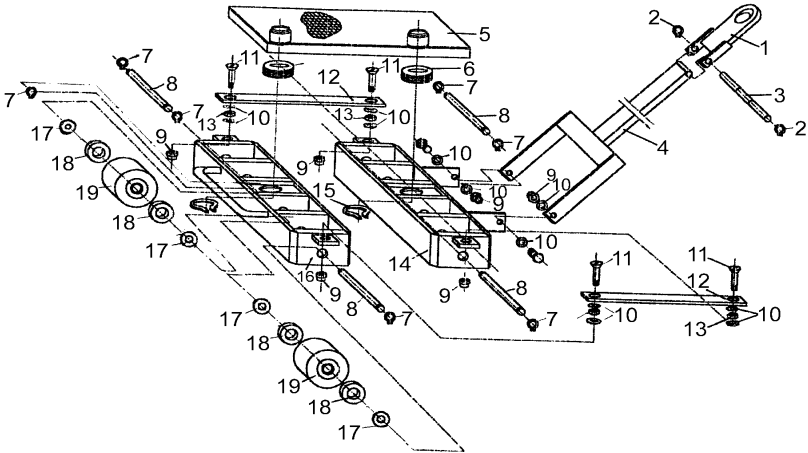

No.	Description	Q'ty
1	Draw base	1
2	Retaining ring 17	2
3	Long axle	1
4	Welded handle	1
5	Pallet rack	1
6	Bearing	2
7	Retaining ring 20	8
8	Axle	4
9	Locknut	6
10	Washer 10	12
11	Screw	4
12	Plate	2
13	Nut	4
14	Left roller bracket	1
15	Retainer	2
16	Right roller bracket	1
17	Washer casing	16
18	Bearing	16
19	Roller	8

### 4.13 Exploded figure of ST120 and parts list

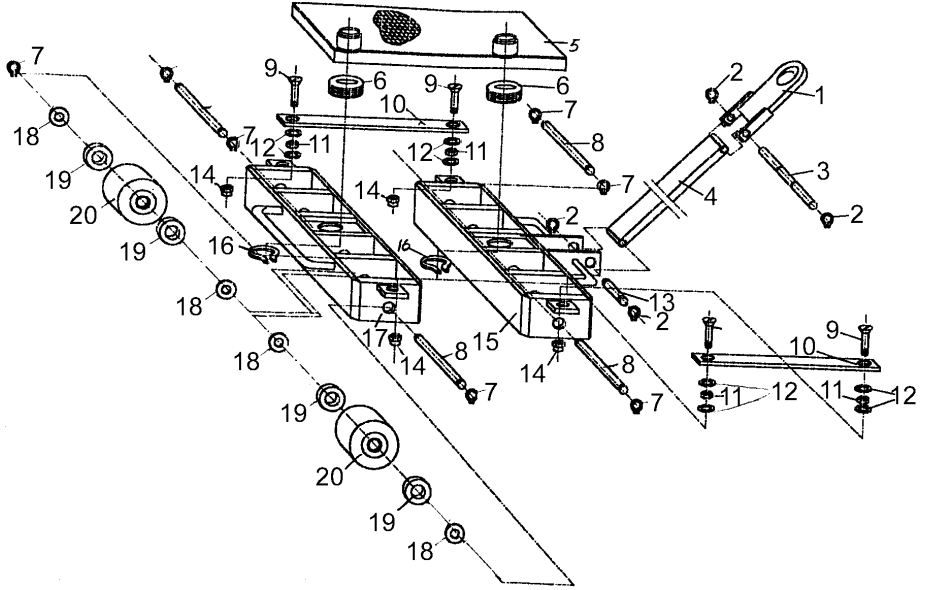

No.	Description	Q'ty	No.	Description	Q'ty
1	Draw base	1	11	Nut	4
2	Retaining ring 17	4	12	Washer 10	8
3	Long axle	1	13	Short axle	1
4	Weld handle	1	14	Locknut	4
5	Pallet rack	1	15	Left roller bracket	1
6	Bearing	2	16	Retaining ring 50	2
7	Retaining ring 20	8	17	Right roller bracket	1
8	Axle	4	18	Washer casing	16
9	Screw	4	19	Bearing	16
10	Plate	2	20	Roller	8



4.14 Exploded figure of RC15 and parts list

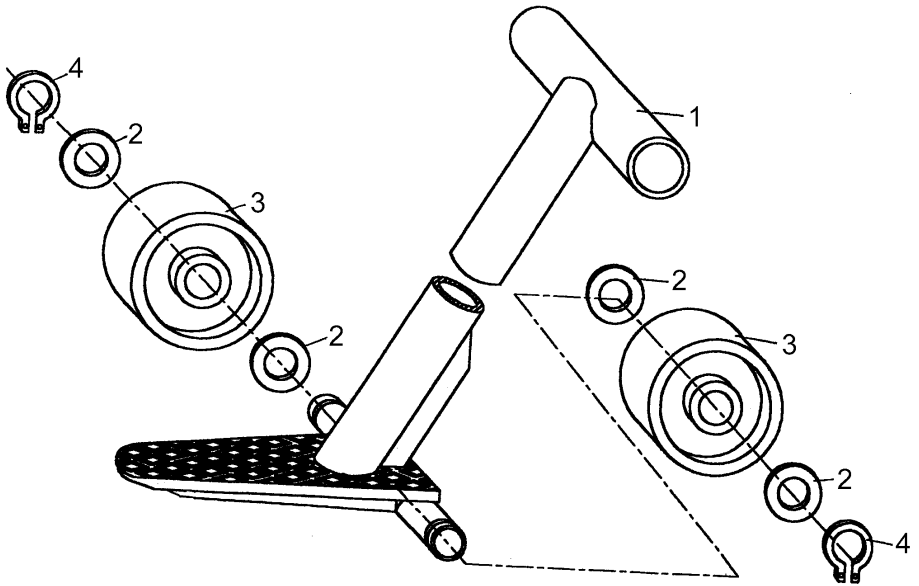

No.	Description	Q'ty
1	Pry bracket	1
2	Washer	4
3	Roller	2
4	Retaining ring	2

4.15 Exploded figure of SK20 and parts list

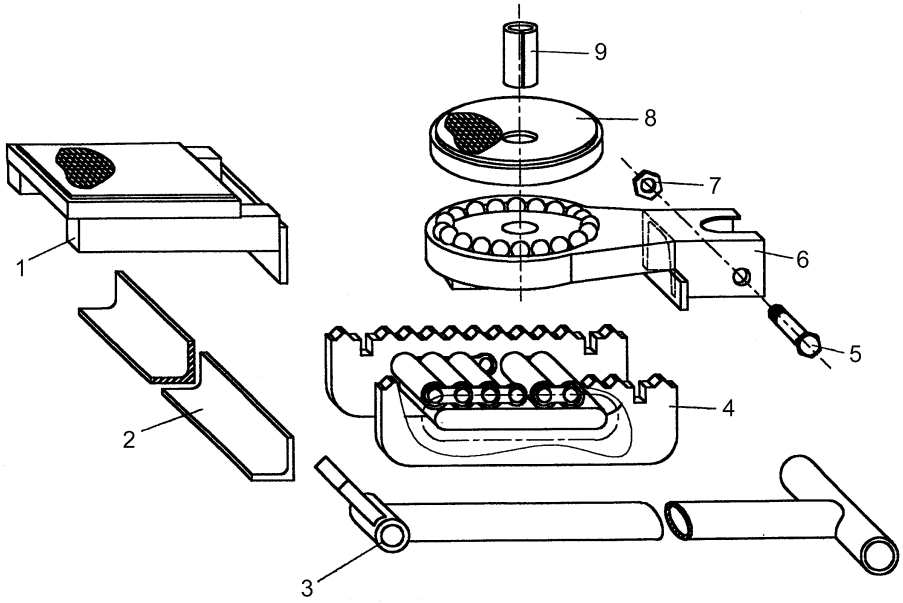

No.	Description	Q'ty
1	Frame	2
2	Angle steel	2
3	Rod	2
4	Roller bracket	4
5	Bolt	2
6	Turn pallet	2
7	Nut	2
8	Disk	2
9	Axle	2

4.16 Exploded figure of SK30 and parts list

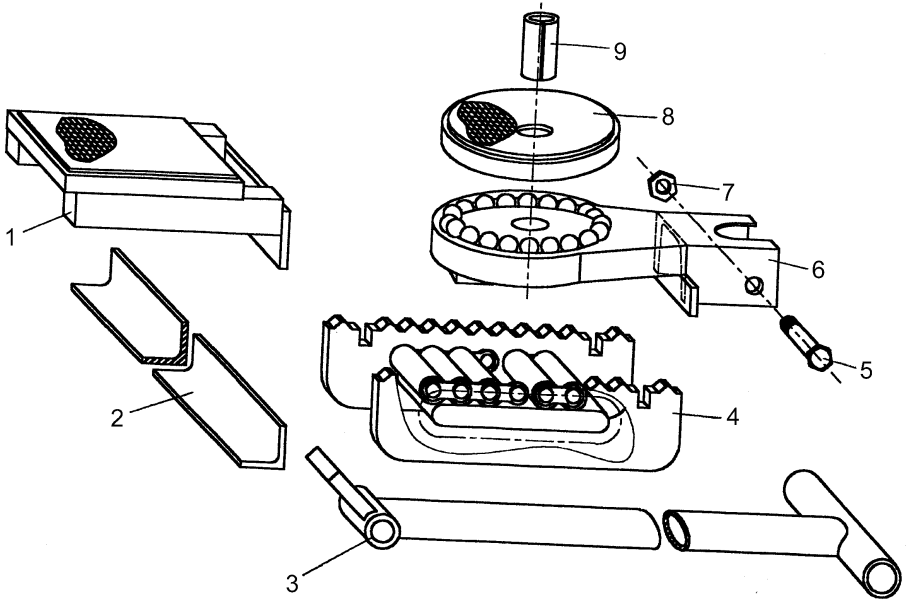

No.	Description	Q'ty
1	Frame	2
2	Angle steel	2
3	Rod	2
4	Roller bracket	4
5	Bolt	2
6	Turn pallet	2
7	Nut	2
8	Disk	2
9	Riveted pipe	2

4.17 Exploded figure of SK60 and parts list

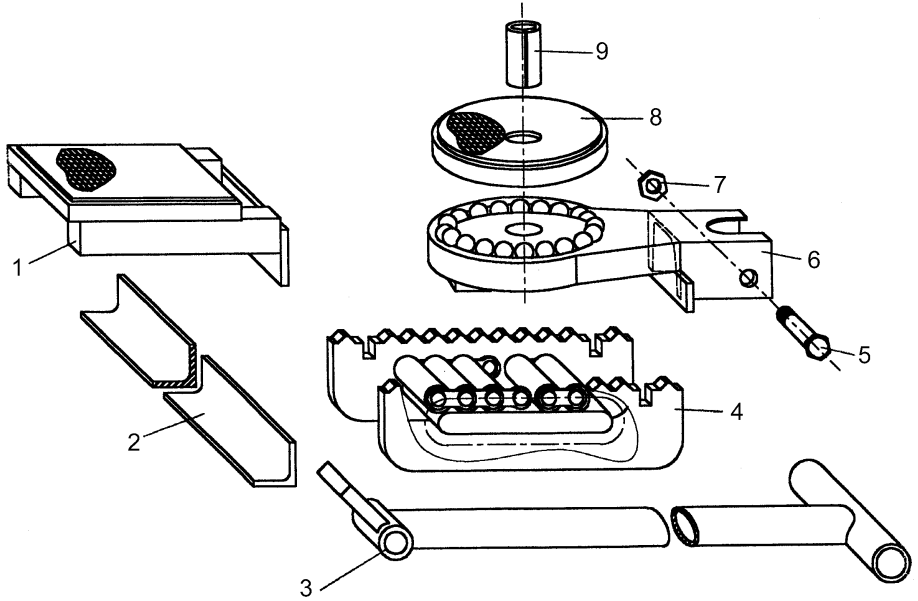

No.	Description	Q'ty
1	Frame	2
2	Angle steel	2
3	Rod	2
4	Roller bracket	4
5	Bolt	2
6	Turn pallet	2
7	Nut	2
8	Disk	2
9	Riveted pipe	2

#### 4.18 Exploded figure of TR40, PC40, RS40 and parts list

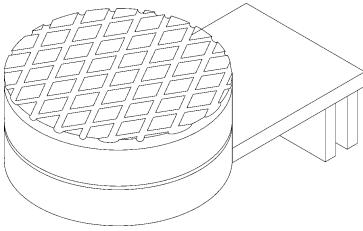

TR40

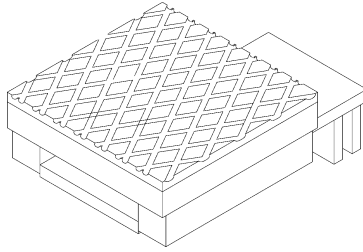

PC40

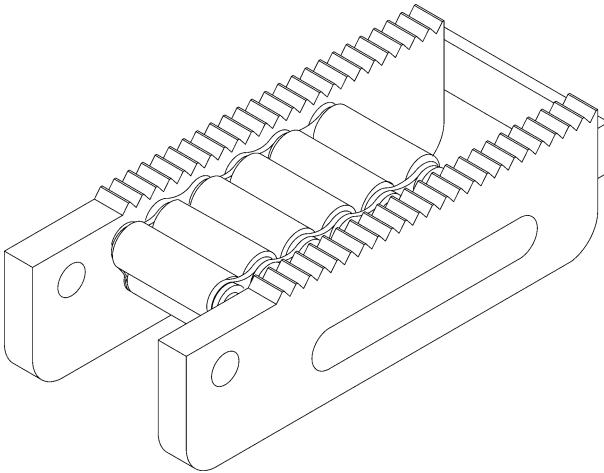

RS40

No.	Description	Q'ty
TR40	Base	1
PC40	Turn pallet	1
RS40	Roller bracket	1

4.19 Exploded figure of TR50, PC50, RS50 and parts list

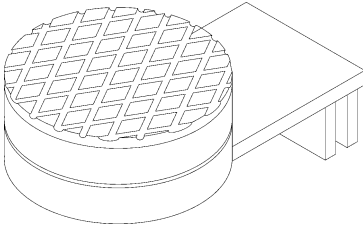

TR50

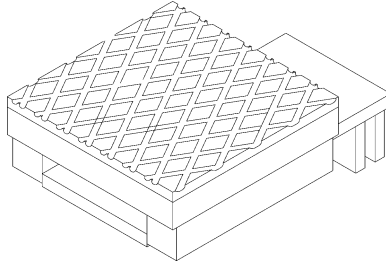

PC50

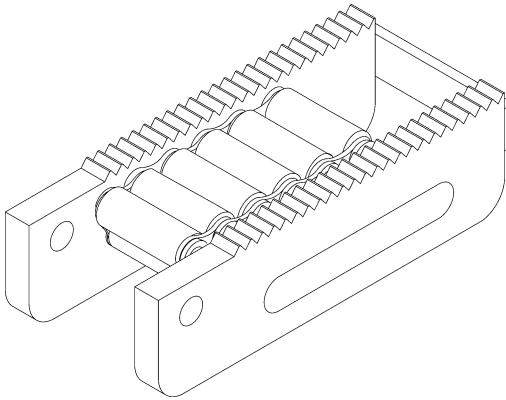

RS50

No.	Description	Q'ty
TR50	Base	1
PC50	Turn pallet	1
RS50	Roller bracket	1

## 4.20 Exploded figure of SR6 and parts list

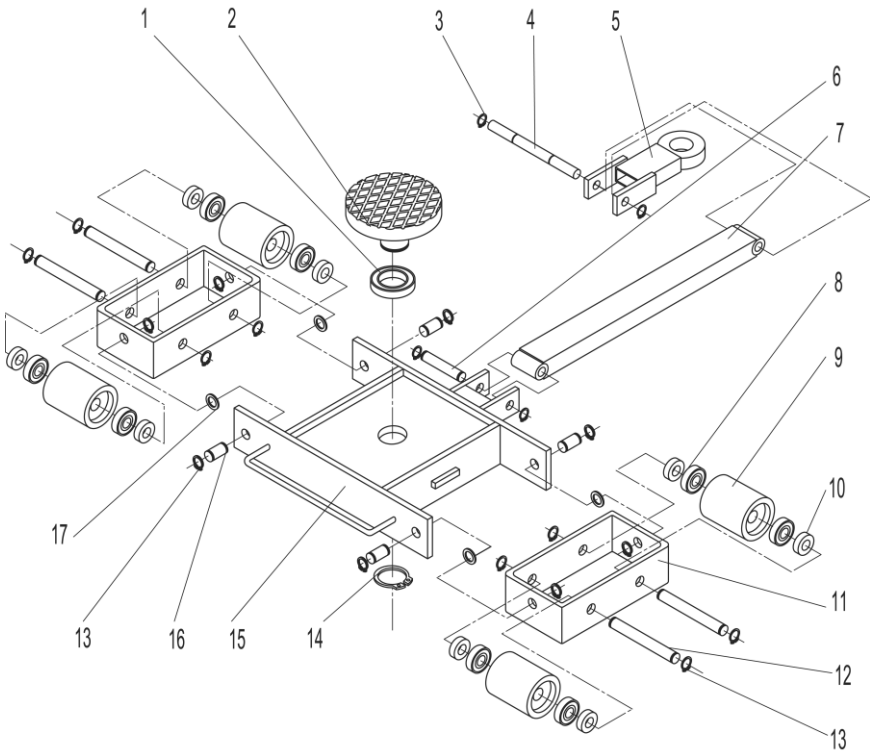

No.	Description	Q'ty	No.	Description	Q'ty
1	Bearing 8210	1	10	Washer casing	8
2	Pallet rack	1	11	Roller bracket	2
3	Retaining ring 18	4	12	Optic axis	4
4	Major axle	1	13	Retaining ring 20	16
5	Draw base	1	14	Retaining ring 50	1
6	Minor axle	1	15	Base frame	1
7	Weld handle	1	16	Pin axle	4
8	Bearing 80304	8	17	Washer 20	4
9	Roller Ø85×85	4			

## 4.21 Exploded figure of SK04 and parts list

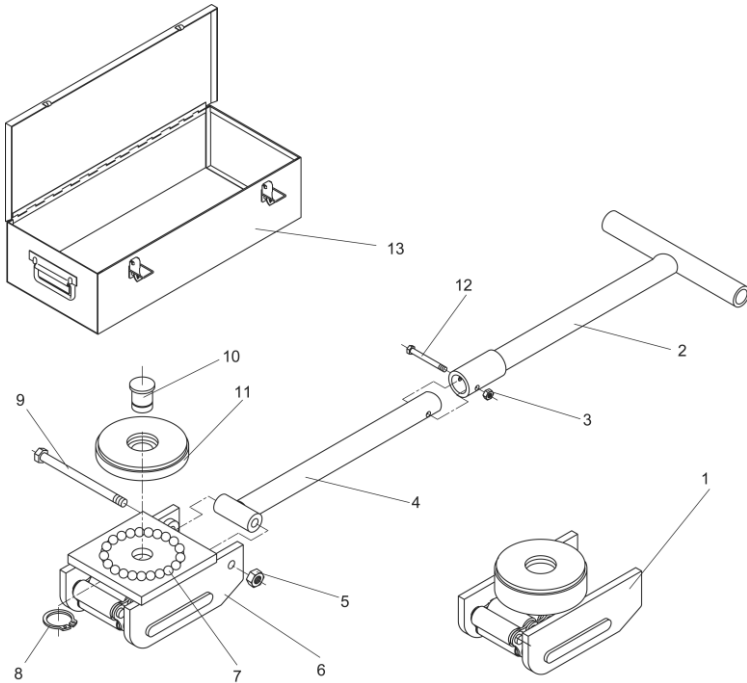

No.	Description	Q'ty	No.	Description	Q'ty
1	Fixed base	2	8	Retaining ring 20	2
2	Upper pull rod	2	9	Bolt M10×110	2
3	Hexagon nut M6	2	10	Axis of gravity	2
4	Bottom pull rod	2	11	Disk assembly	2
5	Nut M10	2	12	Bolt M6×45	2
6	Base	2	13	Iron box	1
7	Steel ball SØ11	44			