

USER GUIDE

Powered platform trolley

PM



NOTE : All information contained in this document is based on the data available at the time of printing. The manufacturer reserves the right to modify its products at any time without notice, obligation, or constraint. Please check our website for any updates.

09.2021

Thank you for buy our product, it is important for you to read and follow all the instructions listed below.

We hope the Electric Platform Cart will make your job easier and more fun. It can boost the productivity in your organization and reduce injuries caused by repetitive pushing or pulling a manual cart with heavy load. Therefore, you will create a happy and safe working environment and minimize the skyrocketing worker's compensation insurance cost.

The Electric Platform Cart is a battery power mobile Platform Cart easily for moving tooling, materials, cargos, parts, or machinery etc from one location to another.

PACKING LIST:

1 Electric Platform Cart, 1 Operating Handle Assembly

1. Specifications:

- 1).Product size: 1200x600x1100mm, platfrom size:1100x600mm
- 2).Plate height: 290mm
- 3).Turning radius: 1000mm
- 4).Charger: 24V, UL or CE Certificate
- 5).Motor:24V/200W
- 6).Max climbing capability: 10°
- 7).Battery: 12V/14AH x 2
- 8).Charge time: 7-8hours
- 9).Continuous working time: 5hours
- 10).**Max.load capacity: 200kg**
- 11).Cart's finish is powder coated
- 12).Curtis Controller 70A, Curtis throttle
- 13).9" nylon front wheel
- 14).5" Caster
- 15).Easy foldable handle with switch box integration
- 16).Adjustable moving speed: 3-6km/h

2. Packaging:

- 1). Packing size: 116x66x85cm
- 2).G.W/N.W: 260/240kg



OPERATION AND FUNCTION OF PARTS:

Press this cross bar to open and fold the handle



1

2

3

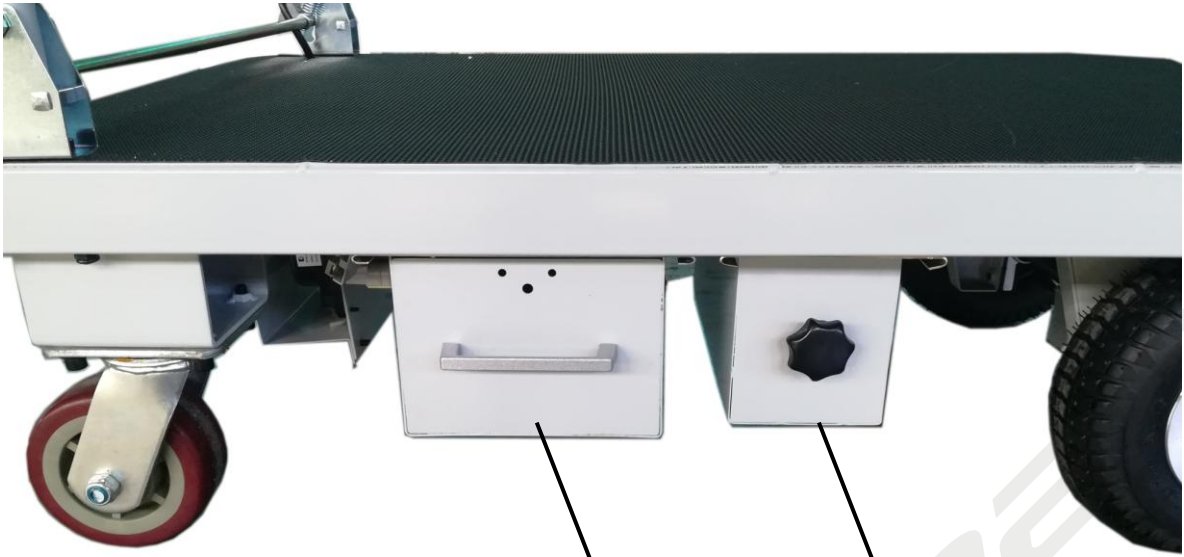

4

5



6

7

8

9

10

11

12

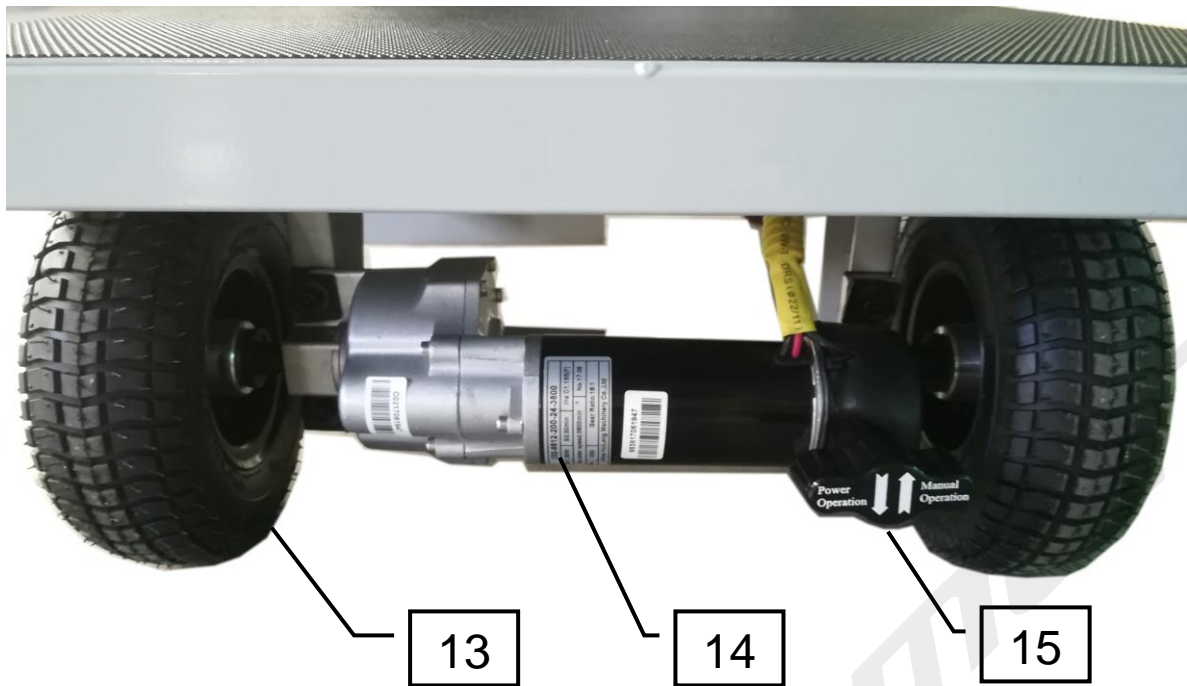

1. Charging socket.
2. Fuse
3. 5" Caster.
4. Battery box —batteries inside.
5. Charger box —charger inside.
6. Battery indicator —needs charge when betteries power is low.
7. Key switch —turn on the power.
8. Working indicator LED.
9. Throttle —rotate to control the cart moving forward or reverse.
10. Moving speed regulator —adjust the moving speed fast or slow.
11. Emergency stop button —stop the cart in case of emergency situation.
12. Yellow button —press it for manual move the cart for a short distance when power on.
13. 9" nylon tire.
14. 24V/200W Transaxle.
15. Clutch of transaxle —exchange the cart from power move to manual move when power off or power finished.

NOTE:

The controller system of the Electric Platform Cart will be in dormant condition if no operation in 3 minutes, need to turn off the key then turn on when use it again.

WARNING:

- DO NOT use the Electric Platform Cart outdoor when rain or wet ground.
- DO NOT try to climb sharp curbs.
- DO NOT drive over obstacles exceeding 5 cm in height.
- DO NOT overload to the Electric Platform Cart.
- DO NOT enter under the Electric Platform Cart.
- DO NOT put foot in front of rolling wheels, injury could result.
- DO NOT make an abrupt change at high speed or while traveling on an incline.
- DO NOT attempt to make fast turn on flat surfaces.
- DO NOT back onto uneven surfaces or inclines.
- DO NOT operate your cart when the working indicator LED is unnormal flashing.



STOCK
The handling company