

# Electric Moving Cart ET400

- Battery Powered
- Large Loading Capacity
- Long Endurance



# Electric Moving Cart ET400

## Item Details



### Carrier

Made Of Alloy Steel Material, Strong and Wear-resistant



### Control Panel

Switch The Running Mode Through The Button  
Control the Moving Cart Through The Joystick  
The Red Button is Emergency Stop Button



Flip Button    Lift Button    Speed Control Button



### Safe Strap

Quickly Pull Out/Stow Away to Secure Cargo



### Electric Push Rod

10000N High Thrust, Fast Speed, Adaptive Thrust Control



### Battery

Play And Plug With Auto Connection Independent Switch, Display battery level and voltage

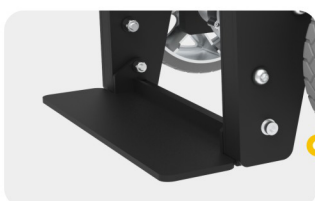

### Loading Plate

Insert Into the Bottom of the Cargo

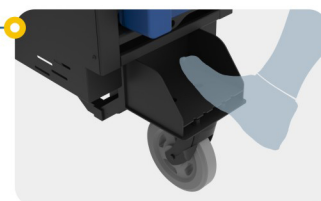

### Footrest Design

Easy To Lift The Cargo



### Driving Wheels

Rubber Drive Wheels With Strong Grip, Anti-corrosion, Anti-slip, Oil-proof, Shock-proof



### Motor Brake

Turn Off The Battery and Push Manually

## Technical Parameter

Model	ET400
Item Weight	104KG
Maximum Capacity	400KG
Battery Capacity (Battery Powered)	Flat Surface Moving: 75 Minutes Climbing On Slope Intermittently: 35 minutes
Running Speed	Low Speed: 1KM/H, High Speed: 4KM/H
Max Crawling Slope	15°
Cargo Loading Method	Electric Push Rod Assisted Flip
Motor Parameter	48V 1300W
Noise Level	<70dB
Protection Grade	IP33

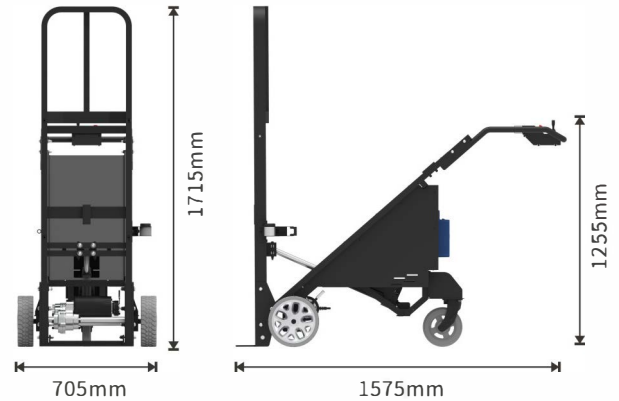

## Optional Fixture-Gas Cylinder



Alloy Steel Material,  
Wear Resistant & Sturdy



Simple Installation,  
Easy Operation



Used to Moving Different  
Gas Cylinders

## ACCESSORIES



### Lithium Battery

Battery Capacity: 48V 10AH

Battery Weight: 3.2KG



### Charger

Input: 100V-240V

Output: 54.6V 4A



### Safety Strap

Size: 55x3700MM

Self-retracting Ratchet Strap



# Electric Moving Cart ET400

## PRODUCT FUNCTIONS

Flat Surface Moving



Electric Flip Cargo



## APPLICATIONS



Warehouse



Factory



Shopping Mall



Hospital

***Specially Customized for the  
Flat Surface Handling of Heavy Objects***

*Motorized Handling is Labor-saving and Safer*



**BetterWay | Ergolift ApS**

Website: [Betterway.dk](http://Betterway.dk)

Email: [info@betterway.dk](mailto:info@betterway.dk)

Tel: +45 44 600 440

