

# Operating Instructions

## Parts List



**Hand Pallet Truck**

**Note: Operator MUST read and understand this operating instructions before use this Hand Pallet Truck.**

Thank you for using our pallet truck. Your pallet truck is made of high quality steel and is designed for the horizontal lifting and transport of loads on a pallet or standardized containers on a level, fixed base. For your safety and correct operation, please carefully read this instruction before using it.

**NOTE: All of the information reported herein is based on data available at the moment of printing. We reserves the right to modify our own products at any moment without notice and incurring in any sanction. So, it is suggested to always verify possible updates.**

## 1. GENERAL SPECIFICATIONS

Capacity	(kg)	2000	2000	2500	2500	3000	3000
Max. Fork Height	(mm)	200( or 190 )					
Min. Fork Height	(mm)	85( or 75 )					
Fork Length	(mm)	1150	1220	1150	1220	1150	1220
Width Overall Forks	(mm)	450 / 520 / 540 / 685					
Individual Fork Width	(mm)	160					
Load Wheel Diameter	(mm)	Ø 82x70(or Ø 74x70) Nylon, Polyurethane					
Steering Wheel Diameter	(mm)	Ø 200(or Ø 180) Nylon, Polyurethane, Rubber					

Special fork length are available 800, 900, 950, 1000, 1500, 2000mm.  
Materials and specification are subject to change without notice.

## 2. TO ATTACH DRAW-BAR TO PUMP UNIT

If you have purchased a wooden box of pallet truck, some assembly is required. Certainly, you need some tools, a hammer, a pliers, a spanner, etc; and some parts, one axle with hole (105), two elastic pins (106)(**Note one is in the axle (105)**), these parts are putted in a plastic bag, which is putted into the draw-bar.

**NOTE: The number of draw-bar and pump should be the same.**

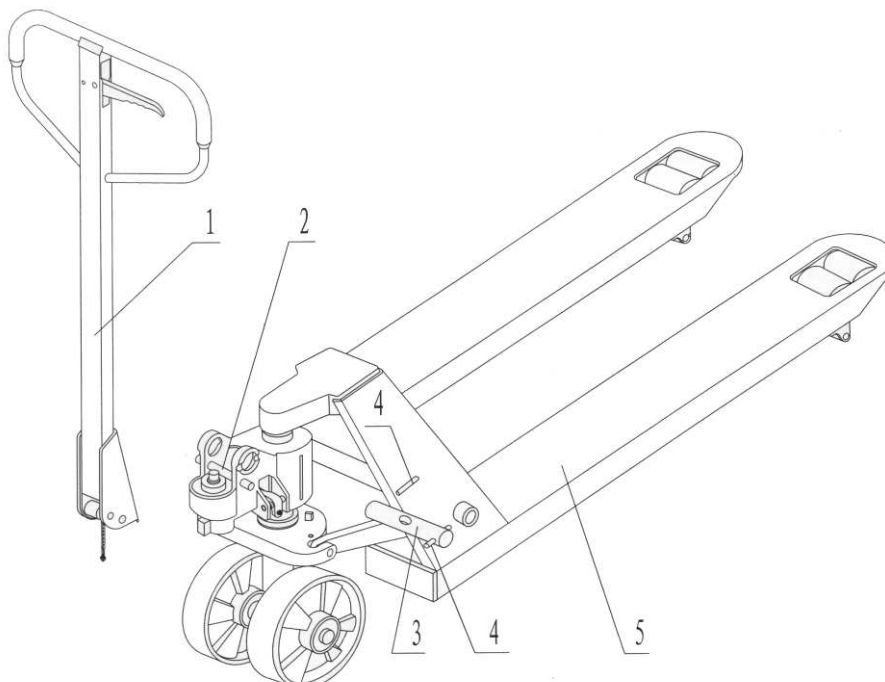

1. Draw-bar 2. Pin 3. Axle with hole 4. Elastic pin 5. Fork frame

Fig. 1

When attaching the handle, you had better squat just behind the pallet truck. Then you:

**2.1** Insert the draw-bar onto the pump piston (303), then use a hammer to insert the axle with hole (105) into the hydraulic pump and draw-bar **from the right to left**. (See fig. 2 ).



Fig. 2

**2.2** Let control handle(117 or 120G) to the '**LOWER**' position, then pass the adjusting nut(104), adjusting bolt(103) and chain(102) through the hole of axle(105) with your hand (See fig. 3).

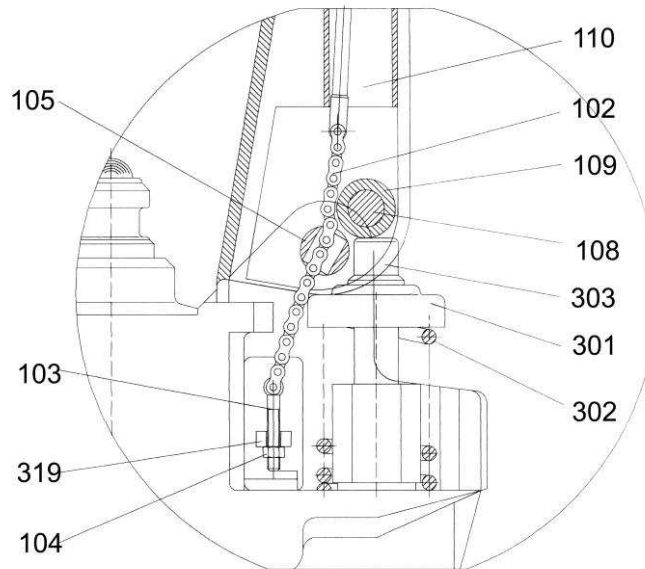

Fig. 3

**2.3** Press the draw-bar (110, 110B or 111G) down, take away the pin(#2) (See Fig. 1).

**2.4** Let the control handle (117 or 120G) on '**RAISE**' position, then raise the lever plate (319) with the pin (#2) and insert the adjusting bolt(103) into the front slot of lever plate (319), note to keep the adjusting nut (104) on the under side of the lever plate.

**2.5** Use a hammer to tap another elastic pin (106) into the axle with hole (105). The draw-bar is now assembled to the pump.

### **3. TO ADJUST RELEASE DEVICE**

On the draw-bar of this pallet truck, you can find the control handle(117 or 120G) which can be regulated in three positions :

- Raise** -handle down
- Drive position** -handle in center position
- Lower** -handle up, the lever moves back the drive position when released.

If however they have been changed, you can adjust according to following step:

**3.1** If the forks elevate while pumping in the **DRIVE** position, turn the adjusting nut (104) on the

adjusting bolt(103) or screw(318) clockwise until pumping action does not raise the forks and the **DRIVE** position functions properly.

- 3.2 If the forks descend while pumping in the **DRIVE** position, turn the nut(104) or screw(318) counter-clockwise until the forks do not lower.
- 3.3 If the forks do not descent when the control handle (117 or 120G) is in the **LOWER** position, turn the nut(104) or screw (318) clockwise until raising the control handle(117 or 120G) lowers the forks. Then check the **DRIVE** position according to item 3.1 and 3.2 to be sure the nut (104) and screw(318) is in the proper position.
- 3.4 If the forks do not elevate while pumping in the **RAISE** position, turn the nut (104) or screw (318) counter-clockwise until the forks elevate while pumping in the **RAISE** position. Then check the **LOWER** and **DRIVE** position according to item 3.1, 3.2 and item 3.3.

## 4. MAINTENANCE

The pallet truck is largely maintenance-free.

### 4.1 OIL

Please check the oil level every six months. The oil can be hydraulic oil: ISO VG32, its viscosity should be 30cSt at 40<sup>o</sup> C, total volume is about 0.4lt.

### 4.2 TO BANISH THE AIR

The air may come into the hydraulic oil because of transportation or pump in upset position. It can cause that the forks do not elevate while pumping in the **RAISE** position. The air can be removed in the following way: let the control handle (117 or 120G) on the **LOWER** position, then move the draw-bar up and down for several times.

### 4.3 DAILY CHECK AND MAINTENANCE

Daily check of the pallet truck can limit wear as much as possible. Special attention should be paid to the wheels, the axles, as thread, rags, etc. It may block the wheels. The forks should be unloaded and lowered in the lowest position when the job is over.

### 4.4 LUBRICATION

All bearings and shafts are provided with long-life grease at the factory. You only need provide with long-life grease at monthly intervals or after each time the truck is cleaned thoroughly to the lubrication points.

## 5 GUIDE TO SAFETY OPERATION

- 5.1 Operator should read all warning signs and instructions here and on the pallet truck before using this truck.
- 5.2 Do not use on a slopping ground.
- 5.3 Do not operate a pallet truck unless you are familiar with it and have been trained or authorized to do so.
- 5.4 Do not operate a pallet truck unless you have checked its condition. Give special attention to the wheels or rollers, the draw-bar unit, the fork unit, the lever plate, etc. .
- 5.5 To pull the truck, always move the control handle into the drive position. This makes the draw-bar easier to move and depressurizes the pump section of the hydraulics. This preserves the hydraulic seals and the valve components. A long service life can be expected.
- 5.6 Do not take up any people on the pallet truck.
- 5.7 The operator had better take on gloves for labor protecting.
- 5.8 When the goods have been transported, all people should be away from the forks for 600mm.
- 5.9 Do not load goods like fig. 5/B .
- 5.10 Do not load over maximum capacity.

5.11 At others special condition or place, the operator should be carefully to operate the pallet truck.

## 6. TROUBLES SHOOTING

No	Trouble	Clause	Fixing Methods
1	The forks can not be up the max. height.	-The hydraulic oil is not enough.	-Pour in the oil.
2	The forks can not be lifted up.	-Without hydraulic oil. -The oil has impurities. -The nut (104) is too high, keep the pumping valve open. -Air come into the hydraulic oil.	-Fill in the oil. -Change the oil. -Adjust the nut(104) or screw (318) (see item 3.4) -Banish the air.(see item 4.2)
3	The forks can not be descended.	-The piston rod(328) or pump (322) is deformed resulting from partial loading slanting to one side or over-loading. -The fork was kept in the high position for long time with piston rod bared to arise in rusting and jamming of the rod. -The adjusting nut (104) or screw (318) is not in correct position.	-Replace the piston rod (328) or pump (322).  -Keeping the fork in the lowest position if not using, and pay more attention to lubricate the rod.  -Adjust the nut (104) or screw (318) (see item 3.3)
4	Leaks	-Sealing parts worn or damaged. -Some part cracked or worn into small.	-Replace with the new one. -Replace with the new one.
5	The fork descends without the release valve worked.	-The impurities in the oil cause the release valve to be unable to close tight. -Some parts of hydraulic system is cracked or bored. -Air come into the oil. -Sealing parts worn or damaged. -The adjusting nut (104) or screw (318) is not in the correct position.	-Replace with new oil.  -Inspect and replace the waste parts. -Banish the air. (See item 4.2) -Replace with the new one. -Adjusting the nut (104) or screw (318). (See item 3.2)

**NOTE: DO NOT ATTEMPT TO REPAIR THE PALLET TRUCK UNLESS YOU ARE TRAINED AND AUTHORIZED TO DO SO.**

Fig. 4

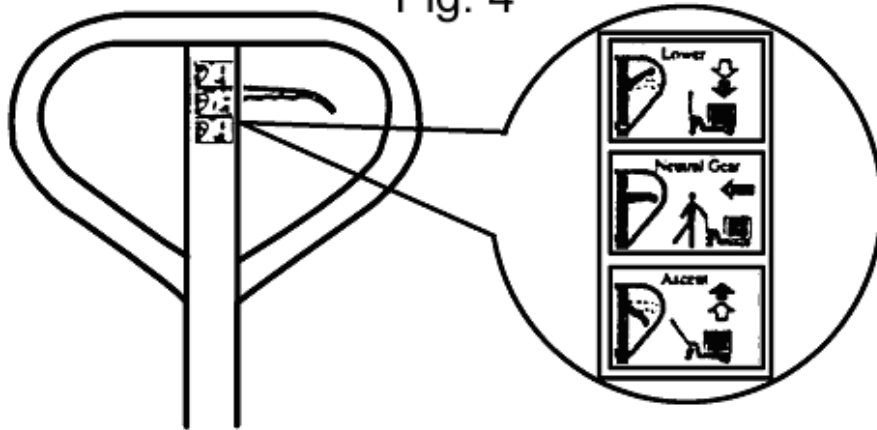
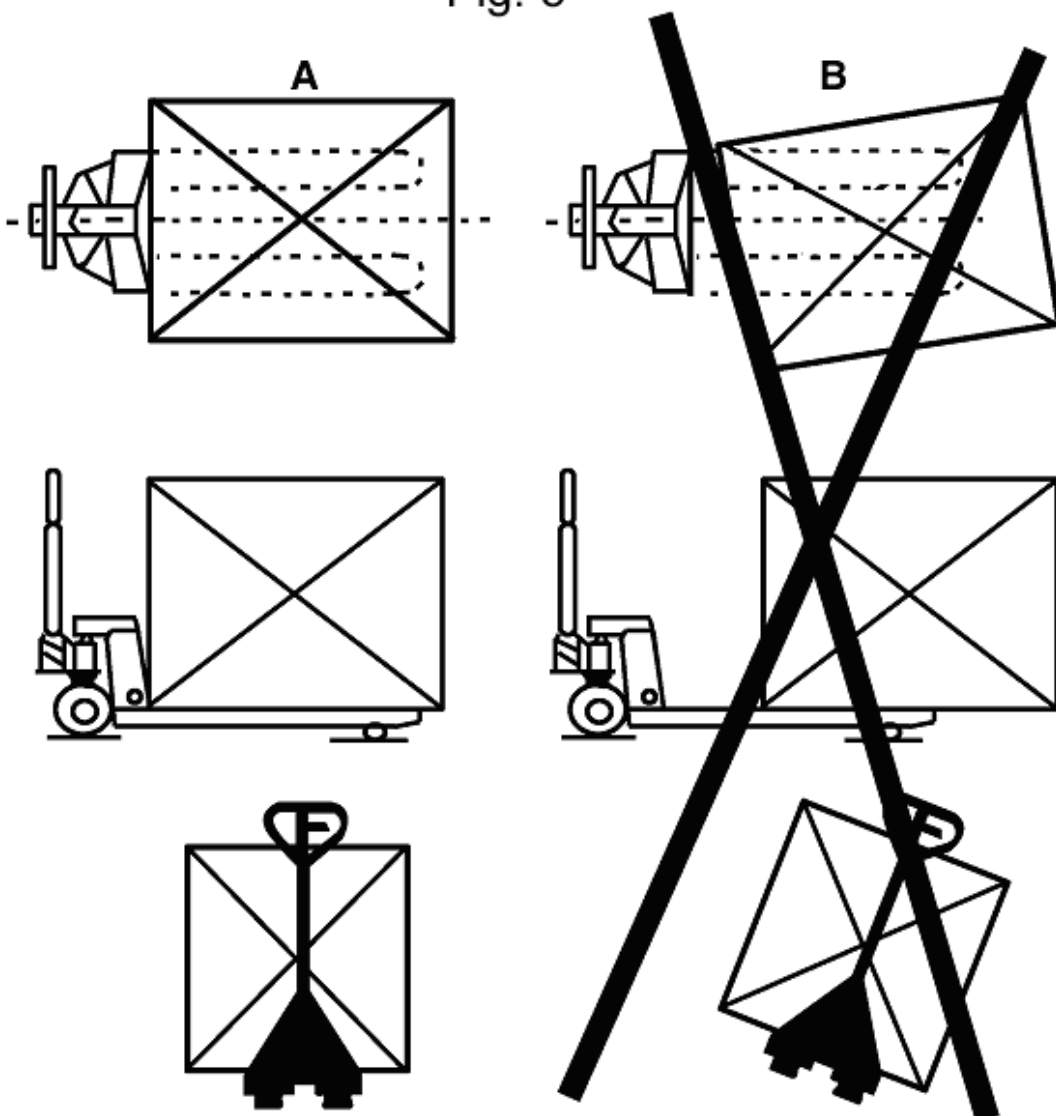
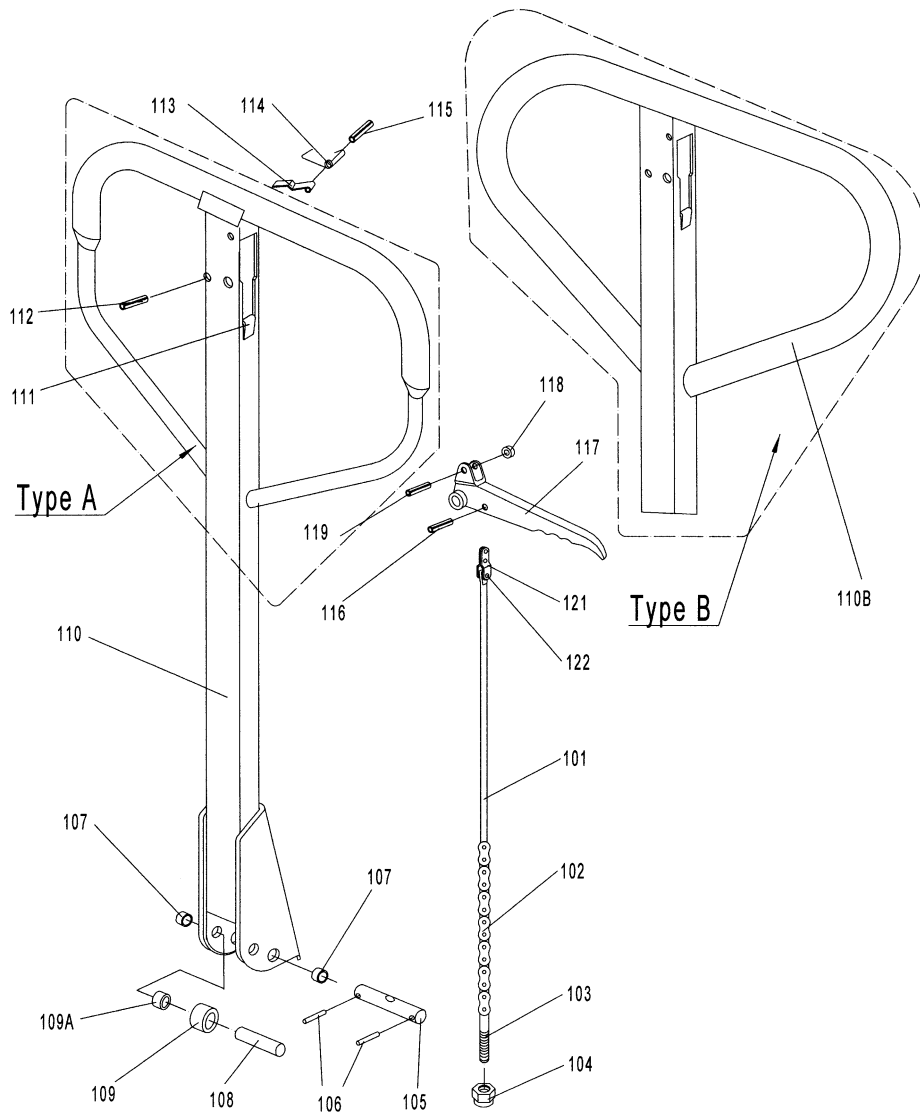

Fig. 5





### LIST of DRAW-BAR

No.	Description	Qty.	Remark
101	Release Rod	1	
102	Chain	1	
103	Adjusting Bolt	1	
104	Adjusting Nut	1	
105	Axle with Hole	1	
106	Elastic Pin	2	
107	Bushing	2	
108	Roller Pin	1	
109	Pressure Roller	1	
109A	Bushing	1	
110	Draw-bar	1	For Type A
110B	Draw-bar	1	For Type B
111	Stop Rubber	1	
112	Elastic Pin	1	
113	Blade Spring	1	
114	Spring	1	
115	Elastic Pin	1	
116	Elastic Pin	1	
117	Control Handle	1	
118	Roller	1	
119	Elastic Pin	1	
120			
121	Pull Board	1	
122	Pin	1	

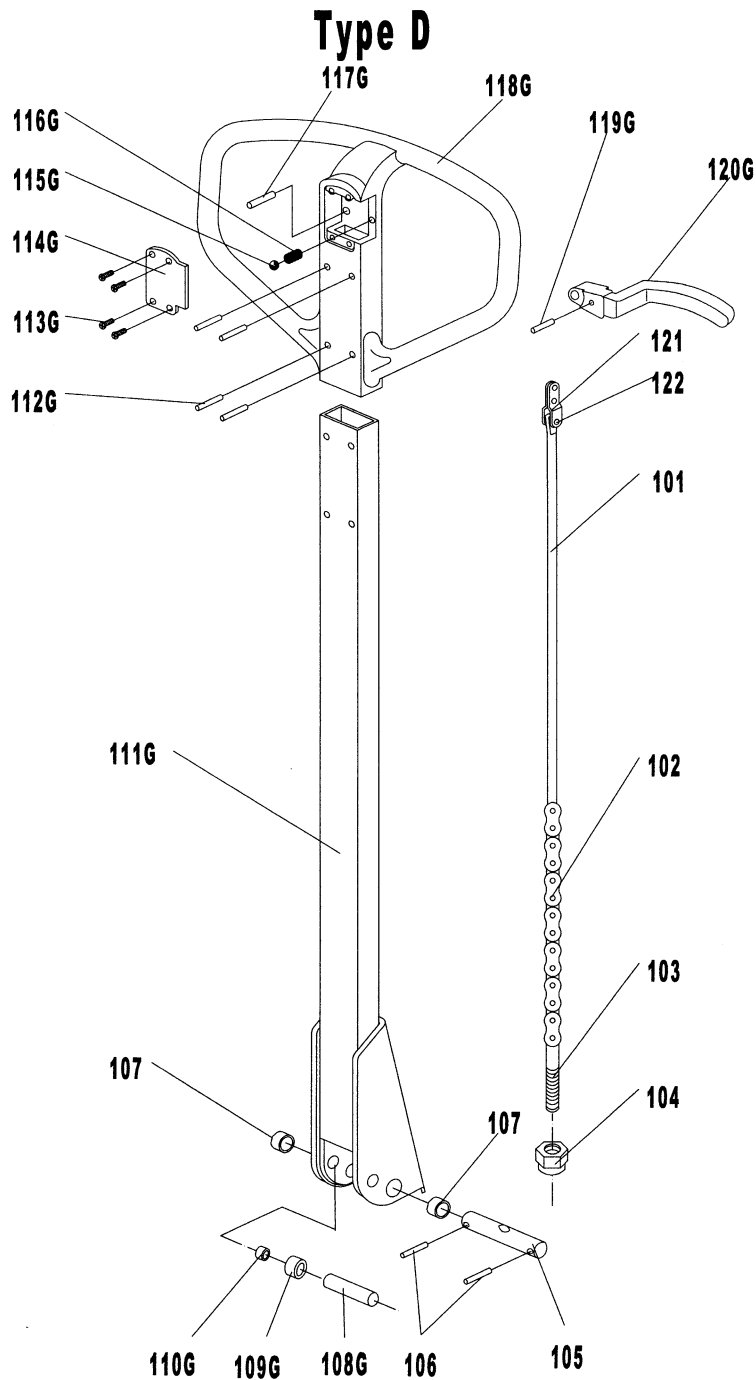

**LIST OF DRAW-BAR for TYPE D**

No.	Description	Qty.	Remark	No.	Description	Qty.	Remark
101	Release Rod	1		113G	Screw	4	For Type D
102	Chain	1		114G	Cover	1	
103	Adjusting Bolt	1		115G	Ball	1	
104	Adjusting Nut	1		116G	Spring	1	
105	Axle with Hole	1		117G	Pin	1	
106	Elastic Pin	2		118G	Handle	1	
107	Bushing	2		119G	Pin	1	
108G	Roller Pin	1	For Type D	120G	Controlling Handle	1	
109G	Pressure Roller	1		121	Pull Board	1	
110G	Bushing	1		122	Pin	1	
111G	Draw - bar	1					
112G	Pin	4					



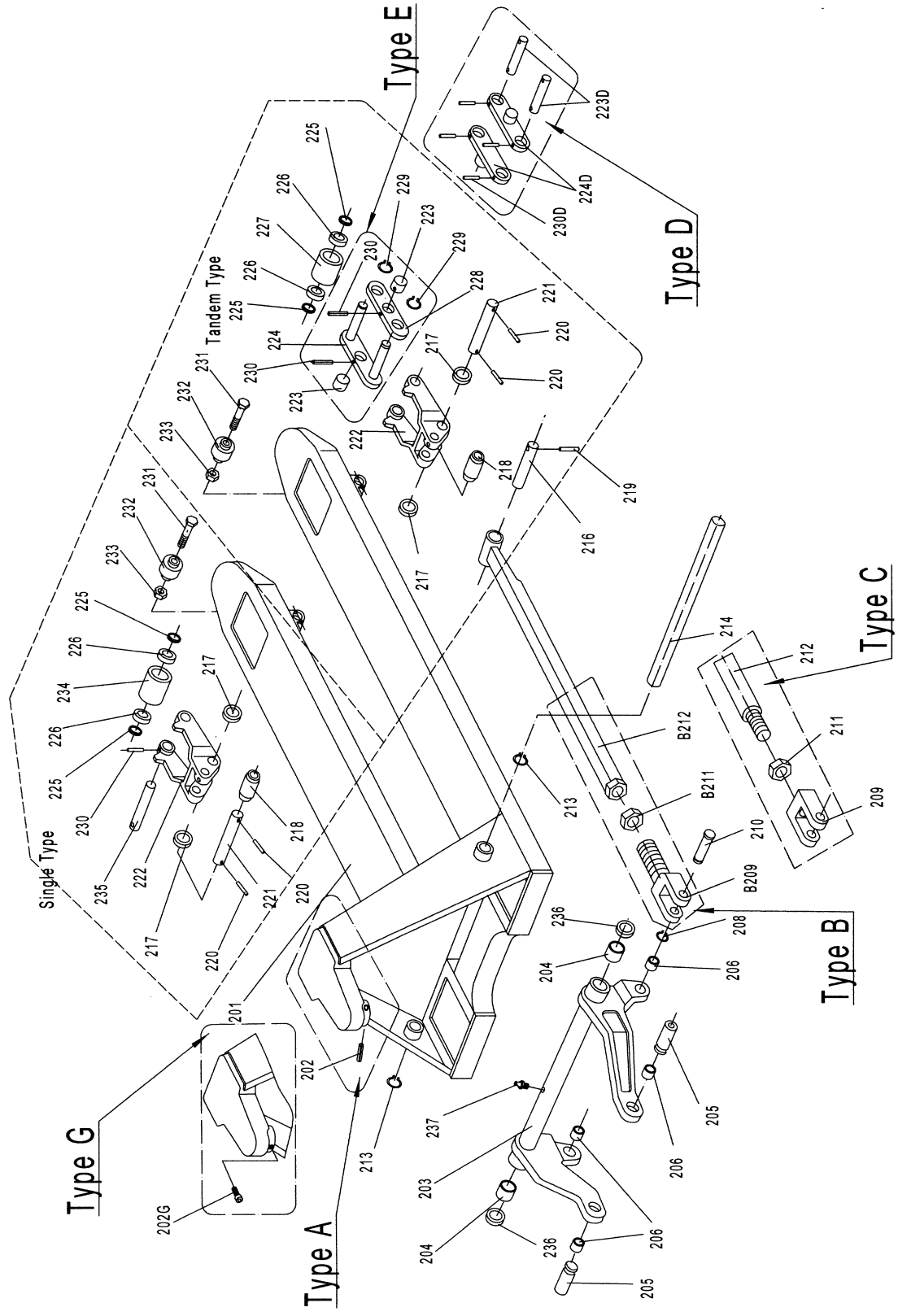

**LIST OF FORK FRAME**

<b>No.</b>	<b>Description</b>	<b>Qty.</b>	<b>Remark</b>
201	Fork Frame	1	
202	Elastic Pin	1	For Type A
202G	Bolt	1	For Type G
203	Rock - Arm	1	
204	Bushing	2	
205	Shaft	2	
206	Bushing	2	
207	Bushing	2	
208	Retaining Ring	2	
210	Pin	2	
209	Joint	2	For Type C
211	Nut	2	
212	Pushing Rod	2	
B209	Joint	2	For Type B
B211	Nut	2	
B212	Pushing Rod	2	
213	Retaining Ring	2	
214	Shaft	1	
215	Bushing	4	
216	Shaft	2	
217	Intermediate Roller	4	
218	Extending Roller	2	
219	Elastic Pin	2	
220	Elastic Pin	4	
221	Shaft	2	
222	Frame of Roller	2	
223*	Shaft	4	For Type E
224*	Tandem Mounting with Pin	2	
228*	Tandem Mounting	2	
229*	Spring Washer	4	
230	Elastic Pin	8 or 2	For Type D
223D*	Shaft for Roller	4	
224D*	Linking Plate	4	
230D	Elastic Pin	8 or 2	
225	Washer	8 or 4	
226	Bearing	8 or 4	
227*	Loading Roller	4	
231	Bolt	2	
232	Enter Roller	2	
233	Locking Nut	2	
234#	Loading Roller	2	
235#	Shaft for Roller	2	
236	Washer	2	
237	Grease Cup	1	

**NOTE: \*-- For double wheel; #-- For single wheel**

# Type A pump

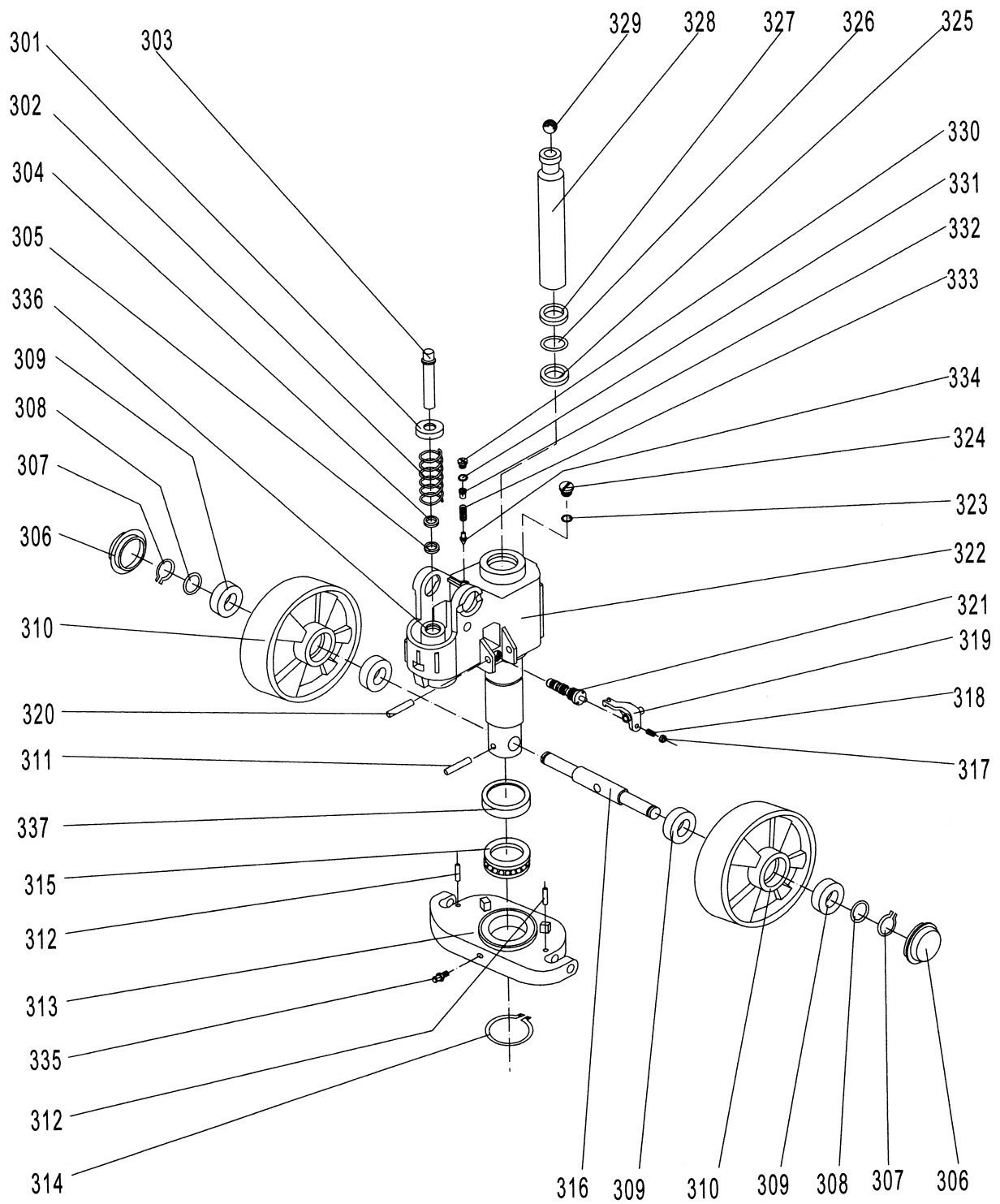

## Type A hydraulic pump

No.	Description	Quantity	Remark
301	Spring Cap	1	
302	Spring	1	
303	Pump Piston	1	
304	Dust Ring	1	
305	Seal	1	
306	Dust Cover	2	
307	Locking Ring	2	
308	Washer	2	
309	Bearing	4	
310	Loading Wheel	2	
311	Elastic Pin	1	
312	Elastic Pin	2	
313	Thrust Plate	1	
314	Retaining Ring	1	
315	Bearing	1	
316	Shaft of loading Wheel	1	
317	Nut	1	
318	Screw	1	
319	Lever Plate	1	
320	Elastic Pin	1	
321	Valve Cartridge	1	
322	Pump Body	1	
323	Seal Washer	1	
324	Screw Plug	1	
325	Seal	1	
326	O – Ring	1	
327	Dust Ring	1	
328	Piston Rod	1	
329	Steel Ball	1	
330	Screw Plug	1	
331	O - Ring	1	
332	Bolt	1	
333	Spring	1	
334	Spindle of Safety Valve	1	
335	Grease Cup	1	
336	Cylinder	1	
337	Cover of Bearing	1	

# Type Y Pump

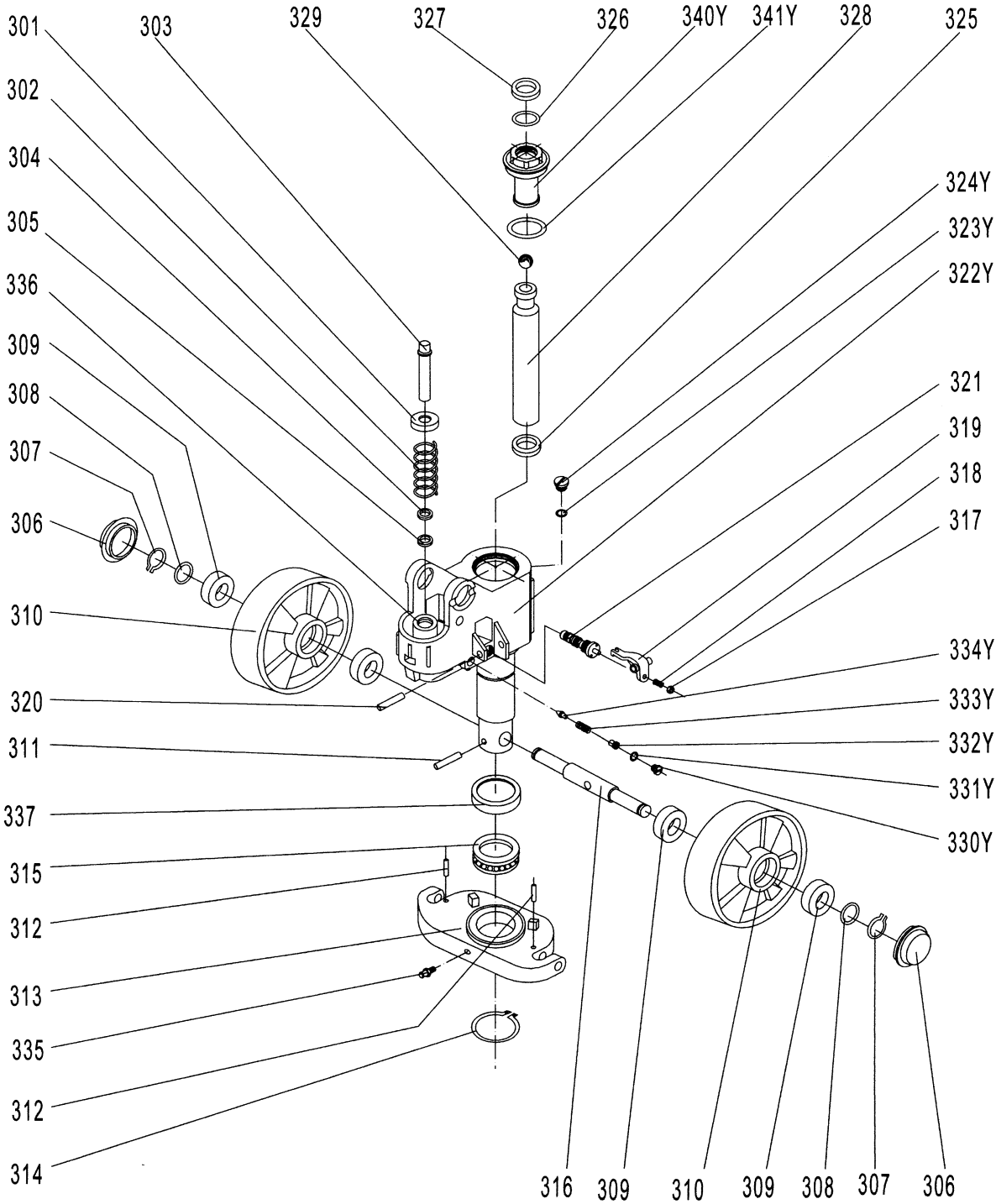

### Type Y hydraulic pump

No.	Description	Qty.	Remark
301	Spring Cap	1	
302	Spring	1	
303	Pump Piston	1	
304	Dust Ring	1	
305	Seal	1	
306	Dust Cover	2	
307	Locking Ring	2	
308	Washer	2	
309	Bearing	4	
310	Loading Wheel	2	
311	Elastic Pin	1	
312	Elastic Pin	2	
313	Thrust Plate	1	
314	Retaining Ring	1	
315	Bearing	1	
316	Shaft of loading Wheel	1	
317	Nut	1	
318	Screw	1	
319	Lever Plate	1	
320	Elastic Pin	1	
321	Valve Cartridge	1	
322Y	Pump Body	1	Only for Type Y Pump
323Y	Seal Washer	1	
324Y	Screw Plug	1	
325	Seal	1	
326	O – Ring	1	
327	Dust Ring	1	
328	Piston Rod	1	
329	Steel Ball	1	
330Y	Screw Plug	1	Only for Type Y Pump
331Y	O - Ring	1	
332Y	Bolt	1	
333Y	Spring	1	
334Y	Spindle of Safety Valve	1	
335	Grease Cup	1	
336	Cylinder	1	
337	Cover of Bearing	1	
340Y	Cover with Screw	1	Only for Type Y Pump
341Y	O - Ring	1	

# Quick Lifting Pump

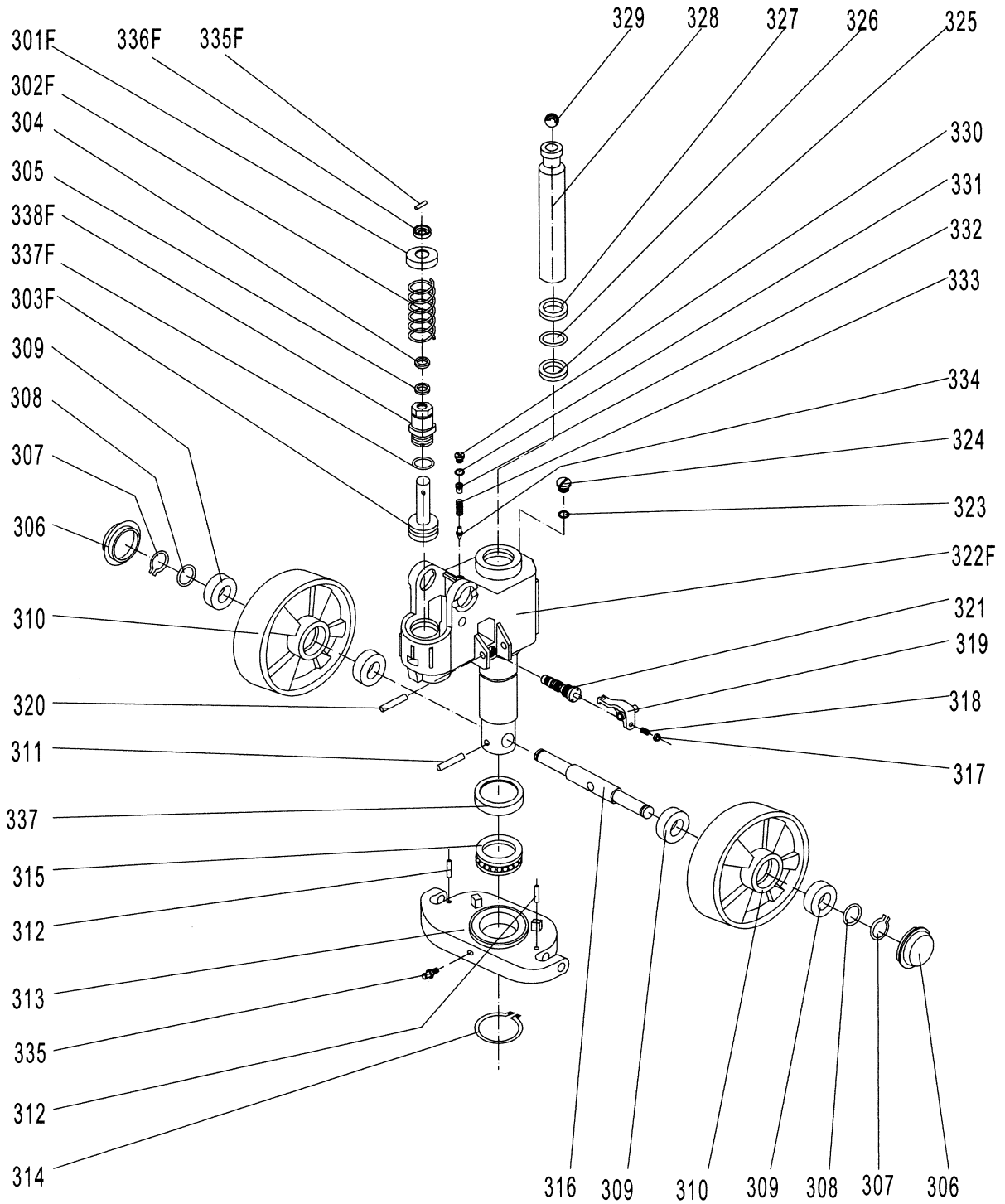

## QUICK LIFTING HYDRAULIC PUMP

No	Description	Qty.	Remark
301F	Spring Cap	1	Only for Quick Lifting Pump
302F	Spring	1	
303F	Pump Piston for Quick Lifting	1	
304	Dust Ring	1	
305	Seal	1	
306	Dust Cover	2	
307	Spring Washer	2	
308	Washer	2	
309	Bearing	4	
310	Loading Wheel	2	
311	Elastic Pin	1	
312	Elastic Pin	2	
313	Thrust Plate	1	
314	Retaining Ring	1	
315	Bearing	1	
316	Shaft of Loading Wheel	1	
317	Nut	1	
318	Screw	1	
319	Lever Plate	1	
320	Elastic Pin	1	
321	Valve Cartridge	1	
322F	Pump for Quick Lifting	1	for Quick Lifting Pump
323	Seal Washer	1	
324	Screw Plug	1	
325	Seal	1	
326	O - Ring	1	
327	Dust Ring	1	
328	Piston Rod	1	
329	Steel Ball	1	
330	Screw Plug	1	
331	O - Ring	1	
332	Bolt	1	
333	Spring	1	
334	Spindle of Safety Valve	1	
335	Grease Cup	1	
337	Cover of Bearing	1	
335F	Pin	1	Only for Quick Lifting Pump
336F	Cap of Pin	1	
337F	O - Ring	1	
338F	Pump Cylinder	1	



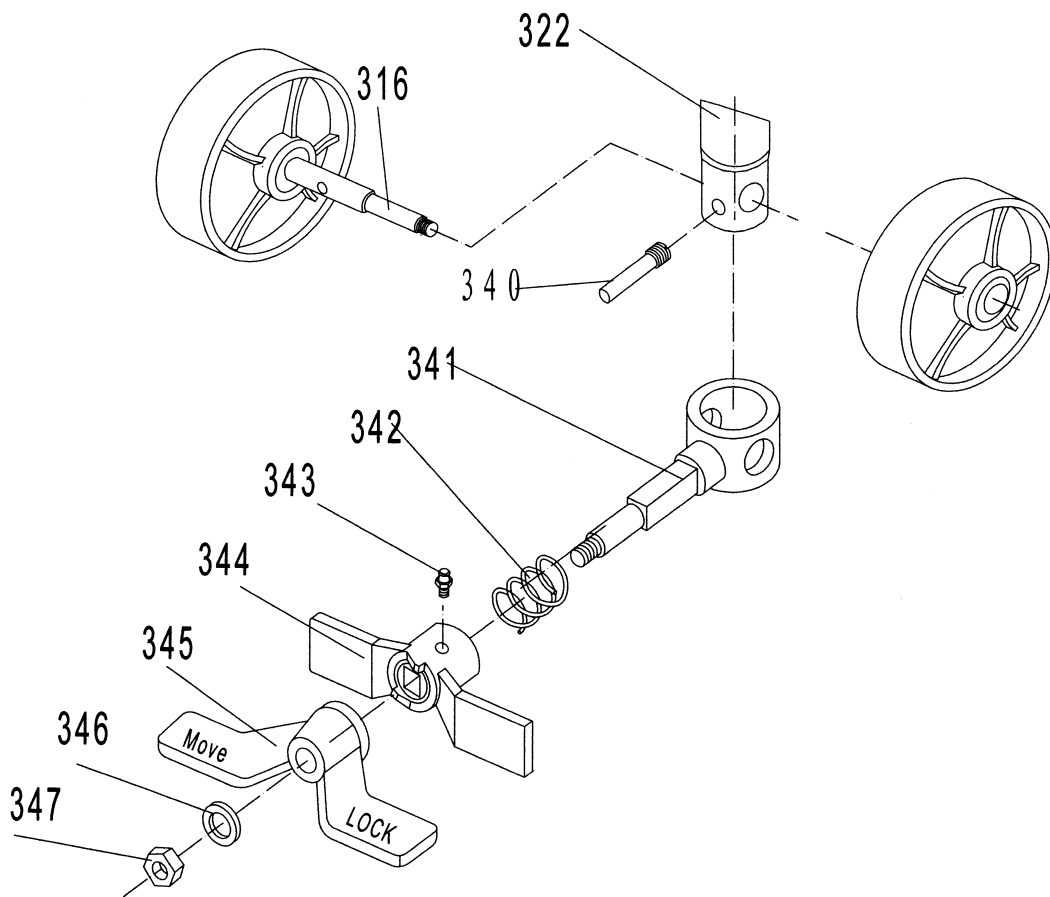

No.	Description	Qty.	No.	Description	Qty.
316	Shaft of Steering Wheel	1	343	Oil - Holder	1
322	Pump Body	1	344	Brake Plate	1
340	Pin	1	345	Pedal	1
341	Holding Sleeve	1	346	Washer	1
342	Spring	1	347	Nut	1

**NOTE:** The foot brake is a additional part, it may not fixed to your pallet truck. If you need it, you should extra order it.