

M-210-CT

BRICK WHEELBARROW REINFORCED

Reinforced Brick wheelbarrow with puncture proof tyre, capacity 200 Kg.

M-210-L4 reinforced brick wheelbarrow with puncture proof tyre.

Loadcapacity: 60-bricks.

Extra shore reinforcement (1).

Beamreinforcement (2).

Handle height: 500mm.

Height: front end 540mm.

Steel rim with double closed ball bearings.

Puncture proof tire (foamed polyurethane).

Wear pads to extend the lifetime of the legs.

Ergonomic natural rubber handles especially devised to the form of your hand.

Finished with a powder coating in grey. (no solvents, less harmful to the environment).

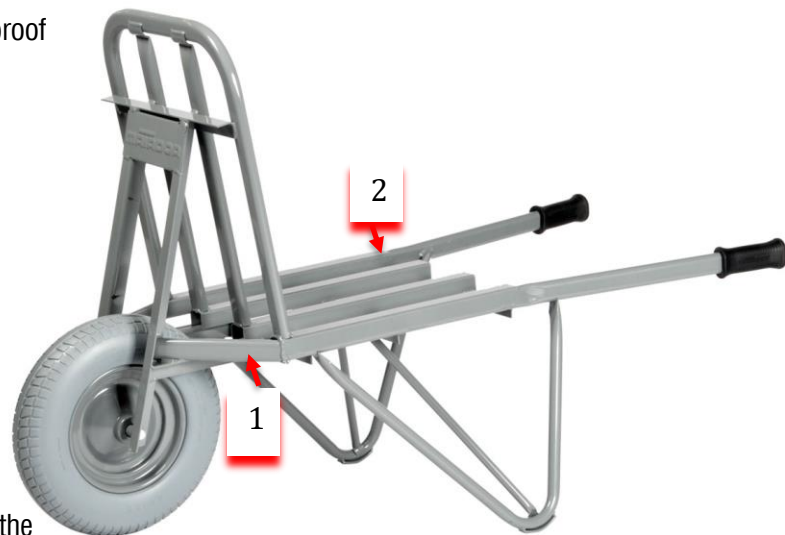

10918
M-210-CT

- * Oval tube (lighter and stronger).
- * Extra shore reinforcement (1).
- * Beamreinforcement (2).
- * Natural rubber handle especially the shape of your hand.
- * Puncture proof tyre (foamed polyurethane).
- * Steel rim with double sealed ball bearings.



11264
M-970-Z-RUB

11189
M-800-CT

| Cap. (kg) | Dimensions overall LxWxH (mm) | Dimensions platform LxWxH (mm) | Weight (kg) | Height front-end (mm) | Wheel Ø (mm) | Wheels | Colour frame | Handgrip LxW (mm) | Article | Article-nr |
|-----------|-------------------------------|--------------------------------|-------------|-----------------------|--------------|----------------|--------------|-------------------|-------------|------------|
| 200 | 1440x600x940 | 450x450 | 19,6 | 540 | 400 | Puncture proof | Gray | 38x20 | M-210-L4 | 10912 |
| 200 | 400x100 | | 3,4 | | 400 | Puncture proof | | | M-800-CT | 11189 |
| | 130x55x38 | | 0,11 | | | | | 38x20 | M-970-Z-RUB | 11264 |