

# AGILA TWIN

2970PJI050P30-11

EAN 4031582418842

Drejelige hjul, Gaffel fremstillet af presset stål, forzinket, blåpassiveret, drejekar med dobbelt kuglekrans, hjulaksel med møtrik, Centerhul.  
Hjulfælg: Polypropylen, Hjulbane: TENTEprene, grå termoplastisk gummi, afsmitningsfri, glideleje



BETTER MOBILITY. BETTER LIFE.



Picture may differ from original product

## Tekniske data

Hjul-Ø	50 mm
Bredde af hjulbane	19 mm
Centerhul-Ø	11 mm
Udladning	25 mm
Udfalddiameter	106 mm
Byggehøjde	69 mm
Temperaturinterval	- 20 / + 60 °C
Standard	EN 12530
Vægt	0.19 kg
Udfalddradius	53 mm
Hjulbane hårdhed	Shore A 87
Belastning (dynamisk)	70 kg
Belastning (statisk)	140 kg

## Egenskaber/fordele

Rullemodstand	● ● ● ○ ○
Kørselsstøj	● ● ● ○ ○
Slid	● ● ● ○ ○
Rustbeskyttelse	● ● ● ○ ○

## Dimensions

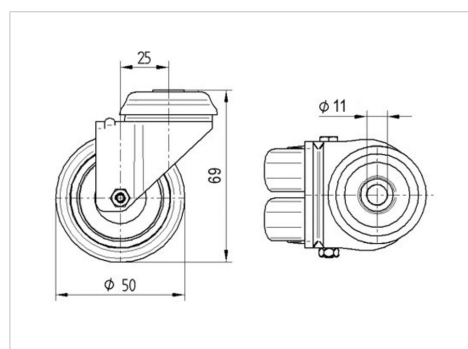

## Structure & Mounting

